

**PRIMUS** WORKBOOK  
OUTDOOR 2010

A PART OF PEOPLE'S  
**ADVENTURE**  
SINCE 1892



*Primus  
was here!*

Primus has been almost everywhere. Where have you been?



[www.primuscamping.com](http://www.primuscamping.com)



<b>Introduction</b>	<b>2-3</b>
<b>News</b>	<b>4</b>
<b>BaumInvest</b>	<b>5</b>
<b>Product categories</b>	<b>6</b>
<b>Eta - A total weight concept</b>	<b>7</b>
<b>Stoves</b>	<b>8-27</b>
<b>Fuel</b>	<b>28-29</b>
<b>Lanterns</b>	<b>30-36</b>
<b>PrimeLite</b>	<b>37-39</b>
<b>Selection guide - PrimeLite</b>	<b>40</b>
<b>PrimeTorch</b>	<b>41-42</b>
<b>Bifrost Tents</b>	<b>43-44</b>
<b>Shelter &amp; Tarp</b>	<b>45-46</b>
<b>SleepRest &amp; SeatRest</b>	<b>46-47</b>
<b>Fashion colour range</b>	<b>48-49</b>
<b>Cooking equipment</b>	<b>50-53</b>
<b>Eating utensils</b>	<b>53-56</b>
<b>Other accessories</b>	<b>56-57</b>
<b>Vacuum bottles</b>	<b>58-61</b>
<b>Spare parts</b>	<b>62-64</b>
<b>Spare parts for old products</b>	<b>65-66</b>
<b>Product summary</b>	<b>67-79</b>
<b>Fuel information</b>	<b>80</b>
<b>Sales material</b>	<b>81-84</b>

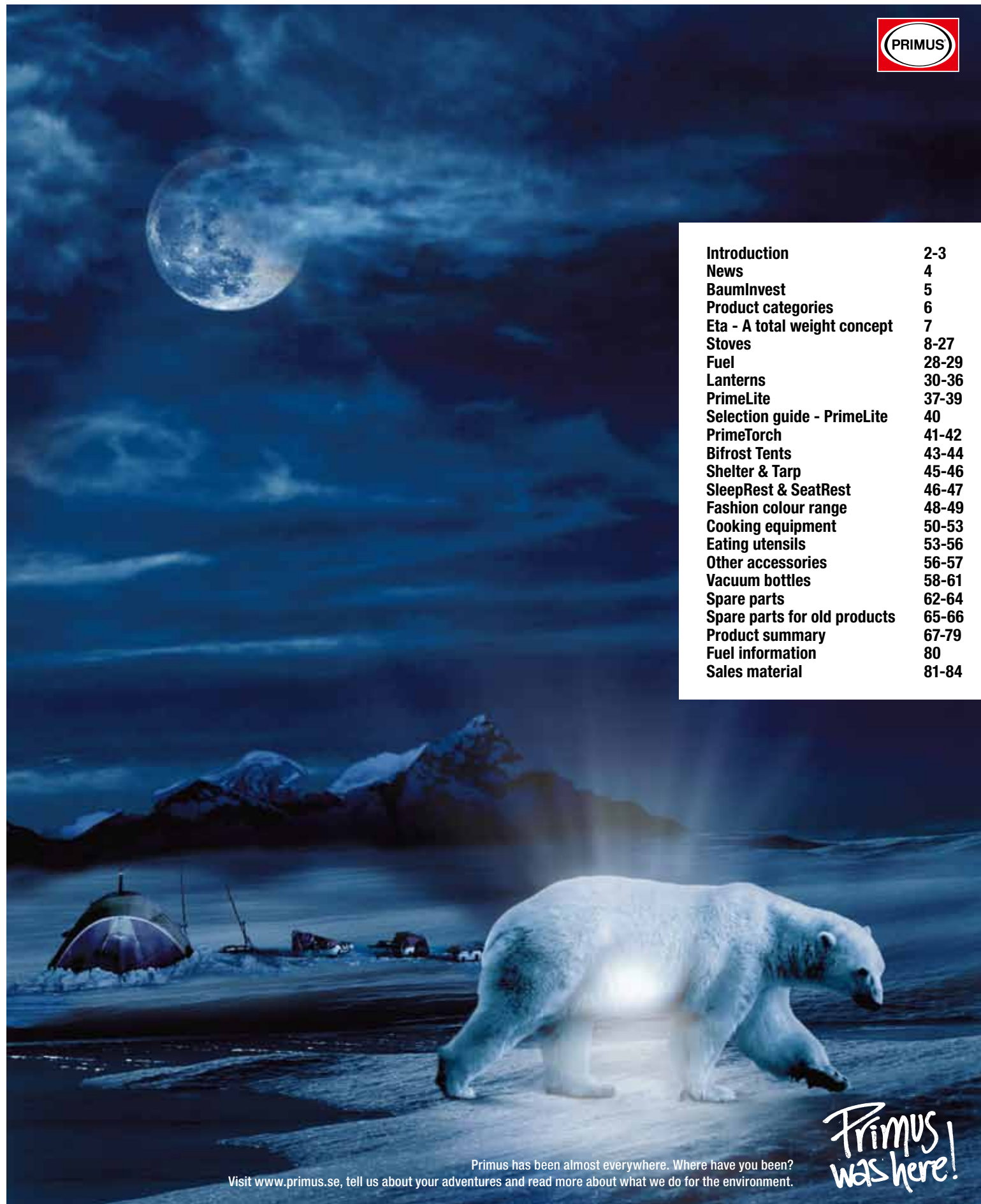

Primus has been almost everywhere. Where have you been?  
Visit [www.primuscamping.com](http://www.primuscamping.com), tell us about your adventures and read more about what we do for the environment.

*Primus  
was here!*

**SYMBOL KEY • LÉGENDE DES SYMBOLES**

	Weight • Poids
	Packing dimensions • Dimensions - plié
	Volume • Volume
	Output • Puissance
	Brightness • Luminosité (lumens)
	Burn time • Autonomie
	With fuel pump • Avec pompe à combustible
	Without fuel pump • Sans pompe à combustible
	Ignition. Piezo igniter: A fixed spark igniter that replaces matches with a simple switch. • Allumage. Allumeur piézo-électrique: Un allumeur fixe à enclencher par une simple pression qui permet de se passer d'allumettes.
	Boiling time. The time it takes for 1 liter of water at 20°C to reach the boiling point. • Temps avant ébullition. Le temps nécessaire pour amener 1 litre d'eau d'une température de 20°C à ébullition.
	Suitable for a number of people • Convient pour nombre de personnes
	Summer: above +/- 0 °C. • Été: supérieur à +/- 0 °C.
	Autumn/spring: generally down to +/- 0°C, temporarily -15°C. • Automne/printemps: généralement jusqu'à +/- 0°C, occasionnellement -15°C.
	Winter: unlimited cold. • Hiver: jusqu'aux températures les plus basses.
	Efficiency classification • Classement d'effectivité
	Type of diode • Type de diode
	Luxeon™ Diode • Diode Luxeon™
	White LEDs • DEL Blanches
	Range • Éclairage
	Red LEDs • DEL Rouges
	Alkaline batteries • Piles alcalines
	Water resistant / Water proof • Résistance à l'eau / Étanche
	Functions • Fonctions



PHOTOGRAPHS COURTESY OF:  
Adventure Family-Pentax (p. 3, 24), Mattias Jansson (p. 50, 65), Per Jessen (p. 3), Till Gottbrath (p. 5, 13),  
Barbro Lindman (p. 5, 19, 50), Meny.se (p. 65), Morgan Sjöström (p. 23), Magnus Österhult (p. 23), Maria Österlind (p. 8)  
PRODUCT PHOTOGRAPHY:  
Ateljé Gabriel Ugglå  
Studio Ljusspel

Primus reserves to itself the right to make changes in the product range, without prior notice, or approval of any kind what so ever, including design and specification changes.  
©Primus AB. All rights reserved. Primus is a trademark of Primus AB, Sweden registered in Sweden and other countries.  
566023

The Fenix Outdoor Group:



# PRIMUS News 2010

## ExpressSpider™

An extremely lightweight, durable hose-mounted gas stove that uses tried and trusted technology. Its well-planned design combines stability, light weight and a small size in your pack.



## Tor Sr. Propane Lantern™

The lantern provides a quiet, adjustable light up to the equivalent of 200 W. They are easy, robust, and heats well in cold areas. With or piezo ignition.



## Field Cup Set

As a response to our Meal Set, the popular new addition to our range from 2009, we now present its accompaniment, the Field Cup Set. The set includes a large and a small cup as well as a knife, fork and spoon. All pieces designed by the Scandinavian designer Nicholai Wiig Hansen.

## Bright colours

A number of our products are now available in bright colours to attract customers in retail stores. The PrimeLite Eye, Commuter Mug, Field Cup Set and Foldable Spork come in six matching colours, which are sure to attract attention!



## ExpressSpider™

Un réchaud extrêmement léger et résistant, monté sur flexible et issu d'une technologie fiable. Un design bien pensé lui donne une construction stable en combinaison avec un poids léger et un faible encombrement.

## MicronLantern™

La Micron Lantern, bientôt légendaire, a fait l'objet d'un nouveau développement. Elle existe ainsi maintenant en verre dépoli afin de répondre à tous les besoins imaginables et d'apporter une lumière plus puissante.



## Field Cup Set

En guise de réponse à la nouveauté populaire de 2009, le Meal Set, une variante arrive maintenant : le Field Cup Set. Le kit comporte une petite et une grande tasse ainsi que couteau, fourchette et cuiller. L'ensemble a été conçu par le designer scandinave Nicholai Wiig Hansen.

## Multicolore

Quelques-uns de nos produits sont maintenant disponibles dans des couleurs vives qui attirent le regard en magasin. PrimeLite Eye, Commuter Mug, Field Cup Set et le Spork pliable existent dans six couleurs coordonnées qui les rendent inimitables.



## PRIMUS' efforts to protect the environment

All kinds of combustion processes produce carbon dioxide, which is the main cause of global warming. That's why PRIMUS introduced a new generation of fuel-efficient stoves in its Eta series in 2007. Most outdoor stoves on the market have an efficiency rating of about 40%. That means that 60% of the energy they produce is wasted. Eta technology helps to reduce fuel consumption dramatically – it's possible to achieve up to 50% savings. That means it produces lower emissions.

But Primus' work to protect the environment doesn't stop there. Together with BaumInvest, we are stepping up to the plate and taking responsibility for our impact on the environment by fully offsetting what little carbon dioxide emissions our Eta stoves do produce. BaumInvest is a foundation that runs a long-term project replanting rainforest in Costa Rica. Its goal is to meet urgent ecological needs, while combining this environmental work with long-term entrepreneurship and commitment to social causes. From 2009, Primus will also donate a sum for each gas cartridge sold.



## La protection de l'environnement par PRIMUS

Tous les types de processus de combustion produisent du dioxyde de carbone qui à son tour contribue en grande partie au réchauffement climatique. C'est pourquoi en 2007, PRIMUS a introduit une nouvelle génération de réchauds à combustion efficace dans la série Eta. La plupart des réchauds de plein air du marché ont un degré d'efficacité d'environ 40%. Ainsi 60% de l'énergie produite est gâchée. Avec la technique Eta, la consommation de combustible diminue énormément – une économie allant jusqu'à 50 % est possible.

Mais la protection de l'environnement par PRIMUS ne s'arrête pas ici : avec l'aide de Bauminvest, l'entreprise prend ses responsabilités envers l'environnement et compense complètement pour les légers rejets de dioxyde de carbone pendant générés par les réchauds Eta. Bauminvest est une fondation qui mène un projet à long terme de reboisement de la forêt tropicale au Costa Rica. Elle s'efforce de remplir les exigences écologiques nécessaires et de combiner celles-ci avec un développement durable et un engagement social. Depuis 2009, Primus fait un don pour chaque cartouche de gaz vendue.



Primus  
was here!

# PRIMUS Product Categories



## Eta™ Category

PRIMUS Eta stoves are the most versatile, fuel-efficient and environmentally friendly stoves available on the market. They are based on the concept of overall total weight, which means that the overall total weight is reduced by reducing fuel consumption. With PRIMUS Eta stoves, you can cook food, not just boil water.

Les réchauds PRIMUS Eta sont les plus universels, les plus économiseurs de combustible et les plus respectueux de l'environnement du marché. Ils sont basés sur un concept de poids total qui comporte une réduction du poids total par la réduction de la consommation du combustible. Avec un réchaud PRIMUS Eta, vous pouvez cuisiner et pas seulement faire bouillir de l'eau.



## Expedition Category

These stoves are developed together with some of the foremost mountain climbers to be lightweight and reliable, even under the most demanding weather conditions. Designed to give you maximum flexibility in the choice of fuel, these stoves have gripping pot supports that keep pots in place on uneven surfaces.

Ces réchauds sont développés en collaboration avec les plus grands alpinistes du monde pour être légers et rester fiables dans les conditions climatiques les plus extrêmes. Conçus pour garantir une grande flexibilité quant au choix du combustible, ils sont dotés de supports de marmites antidérapants et stables même sur les surfaces les plus inégales.



## Lightweight Category

These are lightweight, compact and powerful stoves and lanterns, made for times when every gram and millimeter count.

Très légers, compacts, puissants, conçus pour des situations dans lesquelles chaque gramme, chaque millimètre compte.



# PRIMUS Eta™ – a total weight concept

Type of fuel	Amount of days	Gross weight
LP gas cartridge 220694 - 100 g • 3.5 oz	3	198 g • 7 oz
LP gas cartridge 220794 - 230 g • 8.1 oz	6	390 g • 49 oz
LP gas cartridge 220294 - 450 g • 15.9 oz	12	645 g • 22.7 oz
Fuel bottle 734120 - 0.35 L • 11.3 oz	6	275 g • 9.7 oz
Fuel bottle 721950 - 0.6 L • 20.3 oz	11	493 g • 17.4 oz
Fuel bottle 721960 - 1 L • 33.8 oz	18	841 g • 29.7 oz
Fuel bottle 732530 - 1.5 L • 50.7 oz	28	1300 g • 45.9 oz



Standard stove



PRIMUS EtaPower™ MF

### • High efficiency in all conditions!

By using a thermal camera, you can see that so-called "regular stoves" with an efficiency rate of 40% have larger red zones (warm zones) than the considerably smaller warm zones seen when using an EtaPower stove. Increasing the efficiency rate is about making the most of "warm gas fumes" so that as much of the energy as possible is used for food preparation.

À l'aide d'une caméra infrarouge, on peut voir que les réchauds dits "habituels" avec un degré d'efficacité de 40% ont de plus grandes parties en zone rouge (zone chaude) en comparaison avec les réchauds EtaPower où les zones rouges sont nettement moindres. Le degré d'efficacité accru est dû au fait de placer de la meilleure manière possible les éléments sur les "gaz chauds du réchaud" afin que la plus grande partie de l'énergie soit utilisée à la préparation du repas.

## EtaPower™ pots and pans

As part of Primus's product development and goal of reducing global pollution, our assortment is now being expanded to include fuel-efficient pots. These universal EtaPower pots fit most existing outdoor stoves on the market, such as Primus®, MSR®, Coleman®, Campinggaz® and others. They also reduce fuel consumption and boiling times by up to 50%. This helps all users to reduce their energy consumption and protect our environment. An added bonus is that they are also lighter to pack!

## Casseroles EtaPower™

Dans la lignée du développement des produits Primus et dans le but de réduire la dégradation globale de l'environnement, l'assortiment s'élargit avec des casseroles à économie de combustible. Ces casseroles universelles EtaPower conviennent à plupart des réchauds de camping du marché, tels qu'entre autre Primus®, MSR®, Coleman®, Campinggaz®. Elles diminuent en plus la consommation de combustible et le temps de cuisson jusqu'à 50%. Cela aide chaque utilisateur à réduire sa consommation d'énergie et protège notre environnement. Tel un effet secondaire, un poids d'emballage plus léger est atteint!



1 L • 33.8 oz.



1.2 L • 40.5 oz.



1.7 L • 57.5 oz.



2.1 L • 71 oz.



2.9 L • 98 oz.



# FINALLY!

We love nature. Same as you.

The PRIMUS EtaPackLite™ is a super-small, clever, lightweight stove. The base consists of a burner with automatic piezo ignition, a windscreen, a 1.2-litre pot and a lid that can also be used as a colander. All the pieces fit inside the pot, with room for a 100 g gas cartridge.

With Primus' fuel-efficient burner and the EtaPower™ pot, you'll save on both weight and fuel. And you'll be kinder to the environment, too.







So now you don't need to carry a lot of fuel around with you, which leaves your hands free for other things. Hugging trees, for example.



Primus has been almost everywhere. Where have you been? Visit [www.primus.se](http://www.primus.se), tell us about your adventures and read more about what we do for the environment.

Primus was here!

# PRIMUS EtaPower™ vs. JETBOIL GCS vs. MSR Reactor

	 EtaPackLite	 EtaExpress	 EtaPower MF™	 EtaPower EF™ Trail	 GCS	 Reactor
Liters boiled per 230 g canister	28 L	25 L	28 L	28 L	24 L	22 L
Average cook days per canister	6+	6	6+	6+	4+	4+
1 Liter boil time	2.5 min	2.5 min	2.5 min	2.5 min	5.5 min	3 min
Efficiency	80 %	75 %	80 %	80 %	70 %	71 %
Cost per liter for 28 liters	\$0.21	\$0.35	\$0.21	\$0.21	\$0.50	\$0.54
Maintains efficiency below -15 C	Yes	No	Yes	Yes	No	No
Heat retention in wind over 5 m/s	Yes	Yes	Yes	Yes	No	Yes
Risk of overheating:	No	No	No	No	Yes	No (has emergency shut off)
Pot capacity	1.2 L (or other)	1.0 L (or other)	2.1 (or other)	2.1 / 1.7 L (or other)	1.5 L	1.7 L
Multifuel capacity	No	No	Yes	No	No	No
Interchangeable pots and pans	Yes	Yes	Yes	Yes	No	No
Included in purchase	Cook pot Lid / strainer Windshield Burner	Cook pot Fry pan / lid Windshield Pot Grip Burner	Cook pot Fry pan / lid Windshield Pot Grip Burner Insulated case	Cook pot Fry pan / lid Windshield Pot Grip Burner Insulated case	Cook pot Cozy Lid Burner	Cook pot Lid Burner
Minimum trail weight: stove / pot	404 g	390 g	482 g	528 / 485 g	539 g	567 g
Packed weight with accessories and fuel to boil 26 L	986 g	1098 g	1075 g	1190 / 1070 g	1276 g	1302 g

PRIMUS AB Design and quality in Sweden since 1892

# PRIMUS EtaPower™ MF ❄️



**• Fast cooking**  
**• Low fuel consumption**  
**• Most versatile**  
**• Environmentally friendly**

EtaPower™ MF ❄️	
	932 g • 33 oz 830 g • 29 oz
	∅ 210 x 135 mm • ∅ 8.3" x 5.3"
	1500-2000 W • 5400-7000 BTU/h
	2.5 -3.5 min (+ Pre-heating • Pré-chauffage • Vorwärmung 45-60 sec)
	Manual • Manuel • Manuell extern
	1-4 People • Personnes • Personen
	119 min on 230 g • 8.1 oz gas cartridge • cartouche de gaz • Gaskartusche
352085 EtaPower™ MF - including fuel bottle 734120 352081 EtaPower™ MF - including fuel bottle 734121 (Canadian)	

## The most efficient multifuel stove available

This stove is based on the award-winning EtaPower EF, but it has been refined with a perfectly adjusted preheating coil, an improved burner, and a number of smaller changes from its predecessor. This allows the stove to be used with both gas and liquid fuels, such as white gas, gasoline/petrol and if necessary even kerosene. This in turn leads to even lower fuel consumption and a lower overall weight during hikes, paddling tours and expeditions. The stove comes with a burner, windscreen, 2.1 l • 71 oz EtaPower pot with heat exchanger, frying pan, handle, ErgoPump, 0.35 l • 11.8 oz fuel bottle, multitool, graded plastic bowl and a storage bag that can also be used to insulate the pot.

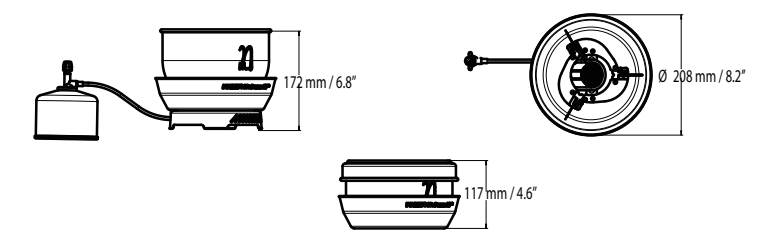

## Le réchaud multifuel le plus efficace disponible

Ce réchaud est basé sur l' EtaPower EF primé mais a été amélioré avec un tube de préchauffage parfaitement calibré, un brûleur développé de nouveau ainsi qu'un certain nombre de petites modifications par rapport à son prédécesseur. Cela permet d'utiliser le réchaud à la fois avec du gaz et du combustible liquide tel que de l'essence raffinée, de l'essence classique et en cas d'urgence du pétrole. Cela donne une consommation de combustible et un poids total encore plus faibles pendant une randonnée, une sortie en kayak ou une expédition. Le réchaud est livré avec un brûleur, un pare-vent, une casserole EtaPower de 2,1 l avec diffuseur de chaleur, une poêle, une poignée, une ErgoPump, une bouteille de combustible de 0,35 l, un outil multi-fonction, un bol gradué en plastique ainsi qu'un sac de rangement qui peut aussi être utilisé pour isoler la casserole.

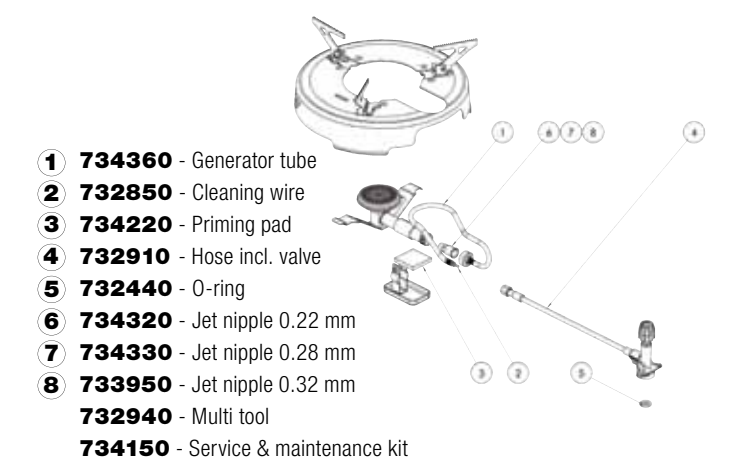









Eta Category

# PRIMUS EtaPower™ EF



- Fast cooking
- Low fuel consumption
- Lightweight
- Environmentally friendly

EtaPower™ EF 	
 830 g • 29 oz 775 g • 27 oz (Trail)	 Ø 210 x 135 mm • Ø 8.3" x 5.3" Ø 210 x 115 mm • Ø 8.3" x 4.5"
 2000 W • 7150 BTU/h	 Piezoelectric • Piézoélectrique • Piezozündung
 2.5 min	 1-4 People • Personnes • Personen
 119 min on 230 g • 8.1 oz gas cartridge • cartouche de gaz • Gaskartusche	
351011 EtaPower™ EF 351083 EtaPower™ EF Trail	

## Simple, effective, and fuel-efficient

The stove's high efficiency rate allows fast boiling times, less fuel consumption and a lower overall weight, which makes it a more environmentally friendly stove on the whole than traditional outdoor stoves. The stove comes with a burner base, windscreen, 2.1 l • 71 oz EtaPower pot with heat exchanger, frying pan, handle, graded plastic bowl and a storage bag that can also be used to insulate the pot.

## Simple, efficace et économiseur de combustible

Le haut degré d'efficacité du réchaud apporte une ébullition rapide, une consommation de combustible plus faible, un poids total plus léger et est considéré dans son ensemble comme plus respectueux de l'environnement qu'un réchaud de camping traditionnel. Le réchaud est livré avec un pied-brûleur, un pare-vent, une casserole EtaPower de 2,1 l avec diffuseur de chaleur, une poêle, une poignée, un bol gradué en plastique ainsi qu'un sac de rangement qui peut aussi être utilisé pour isoler la casserole.

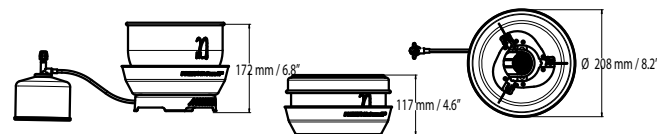

## PRIMUS EtaPower™ EF Trail

EtaPower EF Trail is a lightweight model of the original stove. The frying pan has been replaced by a lid. The pot holds 1.7 l • 57.5 oz and the insulated storage bag has been replaced by a lighter-weight net stuff sack.

EtaPower EF Trail est un modèle poids-léger du réchaud original. La poêle a été remplacée par un couvercle, la casserole contient 1,7 l et le sac de rangement isolant a été remplacé par un filet plus léger.

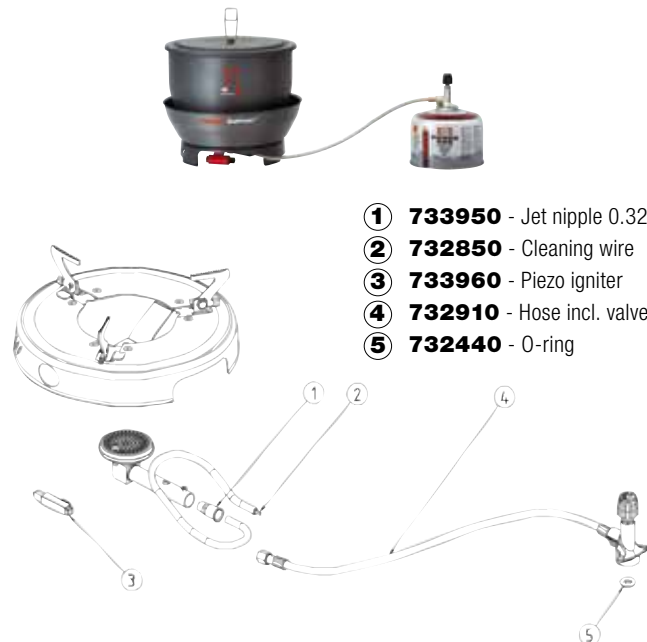









- 1 733950 - Jet nipple 0.32 mm
- 2 732850 - Cleaning wire
- 3 733960 - Piezo igniter
- 4 732910 - Hose incl. valve
- 5 732440 - O-ring

# PRIMUS EtaPackLite™



- Small & compact
- Low fuel consumption
- Lightweight
- Environmentally friendly
- Fast Cooking



EtaPackLite™ 	
 596 g • 21 oz	 Ø 175 x 130 mm • Ø 6.9" x 5.1"
 2000 W • 7150 BTU/h	 Piezoelectric • Piézoélectrique • Piezozündung
 2.5 min	 1-2 People • Personnes • Personen
 119 min on 230 g • 8.1 oz gas cartridge • cartouche de gaz • Gaskartusche	
354083 EtaPackLite™	

## Convenient, stable and efficient

EtaPackLite is a stove that really deserves its name – it's extremely small and easily collapsible. The stove consists of a base with a burner and piezo igniter, windscreen, a 1.2 l • 40.5 oz pot and a lid in sturdy plastic (BPA Free) which can also serve as a colander, with its bayonet fastening. All the components can be packed into the pot, leaving room for a 100 gram gas cartridge. Primus' fuel-efficient burner and the EtaPower pot cut down on weight in your pack, by cutting down on fuel. To protect the non-stick coating, a graded bowl made of hygienic, environmentally friendly polypropylene is included. The bowl also makes an excellent serving bowl.

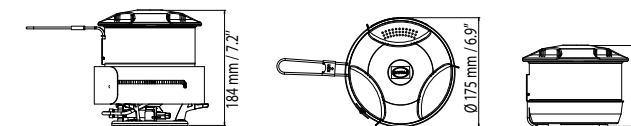

## Souple, stable et efficace

EtaPackLite est un réchaud qui mérite vraiment son nom, puisqu'il est extrêmement petit et léger dans le paquetage. Le réchaud est composé d'une base avec brûleur et allumeur-pièzo, pare-vent, une casserole 1,2 l, ainsi qu'un couvercle en plastique résistant aux chocs qui grâce à son verrouillage à baïonnette fonctionne également comme passoire. Toutes les pièces comprises, ainsi qu'une cartouche de gaz de 100 grammes (non incluse) peuvent être rangées dans la casserole. Grâce au brûleur à économie de combustible de Primus et à la casserole EtaPower, vous économisez du poids en économisant du combustible. Afin de protéger le revêtement « anti-adhérent », un bol gradué inclus en plastique PP hygiénique et respectueux de l'environnement fonctionne remarquablement bien pour préparer le repas.

- 1 733950 - Jet nipple 0.32 mm
- 2 732850 - Cleaning wire
- 3 734640 - Piezo igniter
- 4 732910 - Hose incl. valve
- 5 732440 - O-ring

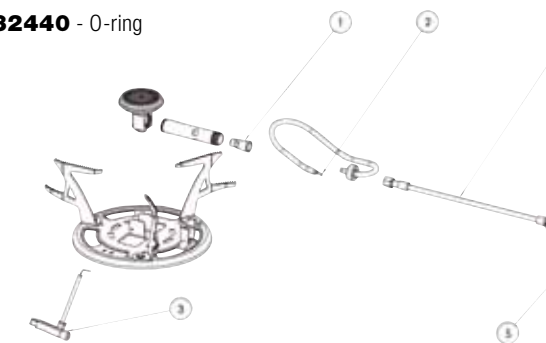









# PRIMUS EtaExpress™



- Fast cooking
- Low fuel consumption
- Lightweight
- Environmentally friendly



EtaExpress™ 	
 430 g • 15.2 oz	 Ø 125 x 160 mm • Ø 4.9" x 6.3"
 2600 W • 8900 BTU/h	 Piezoelectric • Piézoélectrique • Piezozündung
 2.5 min	 1-2 People • Personnes • Personen
 85 min on 230 g • 8.1 oz gas cartridge • cartouche de gaz • Gaskartusche	
<b>353083</b> EtaExpress™	

Eta Category

## Small, light, and minimal fuel consumption for solo trips

EtaExpress includes a stove that mounts directly on the gas cartridge, a wind-screen for maximum fuel savings, and even a 1 liter pot. The lid can also be used as a frying pan. Both the pot and the frying pan are coated on the inside with a three layer titanium nonstick surface. All of the components, as well as a 230 gram gas cartridge, can be packed into the pot. For best fuel economy, turn the throttle approx. 3/4 open. Like all other Eta stoves, you can hang the EtaExpress using the PRIMUS Suspension kit. Comes with a net stuff sack.

## Une consommation de combustible faible, légère et minimale pour les randonnées en solo.

EtaExpress est constitué d'un réchaud qui est monté directement sur la cartouche de gaz, d'un pare-vent afin d'économiser au maximum le combustible et également d'une casserole d'un litre. Le couvercle peut aussi être utilisé comme poêle à frire. La casserole et la poêle ont toutes les deux un revêtement intérieur de trois couches en titane "non-adhésif". Toutes les pièces, ainsi qu'une cartouche de gaz de 230 grammes peuvent être rangées dans la casserole. Pour une meilleure économie de combustible, une utilisation du gaz au 3/4 doit être utilisée. EtaExpress peut comme tous les autres réchauds Eta être suspendu par le système d'accrochage PRIMUS. Livré avec un filet.

- 1 732110 - Piezo igniter
- 2 734350 - Jet nipple 0.32 mm
- 3 732440 - O-ring

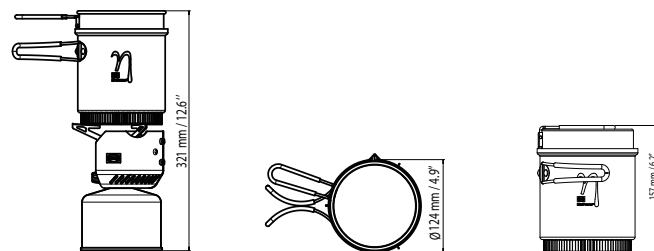

Accepts coffee press #224583

# PRIMUS OmniFuel™



- Super simmering
- All fuels
- Extremely reliable











B Eta™ pot  
↑  
D Standard pot

## PRIMUS OmniFuel™ – 328985

Super Pouch 733910 and fuel bottle 721950 included



OmniFuel™ 	
 441 g • 15.6 oz	 145 x 88 x 70 mm • 5.7" x 3.4" x 2.8"
 3000 W • 10500 BTU/h	 Manual • Manuel • Manuell extern
 3 min (+ Pre-heating • Pré-chauffage • Vorwärmung 40 sec)	 1-4 People • Personnes • Personen
 70 min on 230 g • 8.1 oz gas cartridge • cartouche de gaz • Gaskartusche	
<b>328984</b> OmniFuel™	
<b>328985</b> OmniFuel™ - incl. fuel bottle 721950 and Super Pouch 733910	

Expedition Category

## Our most advanced multi-fuel stove

OmniFuel uses very advanced materials to offer advanced functionality. It is designed to handle demanding conditions, extreme altitudes and both high and low temperatures. OmniFuel is a sturdy stove that works with gas, gasoline/petrol, diesel and kerosene – even aviation fuel. Using the separate control knob, the flame can be adjusted to provide the exact heat required. The Ergo-Pump, the multi-tool with an integrated cleaning needle, nylon stuff sack and the windscreen and heat reflector are included.

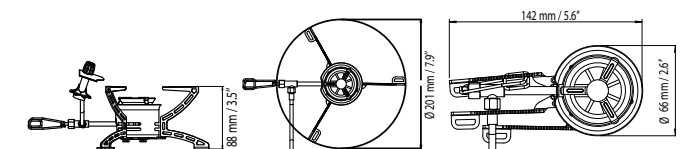

## Notre réchaud multi-combustible le plus avancé

Le réchaud fait appel à des matériaux très élaborés lui permettant d'offrir des fonctions de pointe. L'OmniFuel a été conçu pour fonctionner dans les conditions les plus rigoureuses, aux altitudes les plus hautes et aux températures les plus extrêmes. L'OmniFuel est robuste et capable de fonctionner avec du GPL, de l'essence/du pétrole, du kérosène, du gaz et même avec du carburant d'avion. Un bouton de réglage séparé permet un réglage fin de la flamme permettant d'obtenir exactement la chaleur nécessaire. Livré avec ErgoPump, multi-outils avec aiguille de nettoyage intégrée, pare-vent, réflecteur de chaleur et filet en nylon.

- 1 731870 - Flame spreader
- 2 730670 - Jet nipple 0.28 mm
- 3 731800 - Jet nipple 0.37 mm
- 4 731790 - Jet nipple 0.45 mm
- 5 731890 - Fuel filter
- 6 731780 - Priming pad
- 7 731880 - Holder for priming pad
- 8 732010 - Stove body
- 9 732440 - O-ring
- 10 731930 - Hose incl. valve
- 11 731900 - Spindle incl. o-ring
- 12 731940 - Brass screw
- 13 731920 - Thread handle
- 731860 - Multi tool
- 731910 - Cleaning needle
- 731770 - Service & maintenance kit

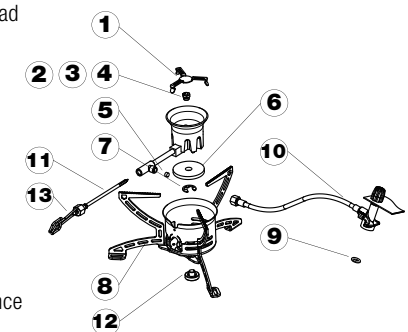

# PRIMUS MultiFuel EX ❄️

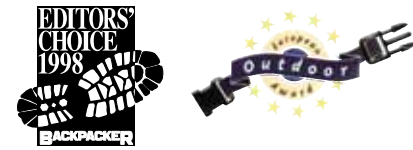

- Versatile
- Stable
- Durable

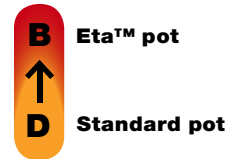

MultiFuel EX ❄️	
🍲	458 g • 16.2 oz
🍲	356 g • 12.6 oz
🔥	3000 W • 10500 BTU/h
🕒	3 min (+ Pre-heating • Pré-chauffage • Vorwärmung 40 sec)
👤	1-4 People • Personnes • Personen
🕒	70 min on 230 g • 8.1 oz gas cartridge • cartouche de gaz • Gaskartusche
328894 MultiFuel EX	



Expedition Category

## MultiFuel EX

MultiFuel EX is a sturdy stove that works with gas, gasoline/petrol, diesel and kerosene – even aviation fuel. It produces a powerful flame and works very well, even in extreme weather conditions. Other advantages include a wind-screen, which has reduced the stove's pack measurements while making it quieter to use. ErgoPump, multitool, nylon bag, windscreen, and heat reflector included.

## MultiFuel EX

Le MultiFuel EX est robuste et capable de fonctionner avec du GPL, de l'essence, du pétrole, du kérosène, du gaz et même avec du carburant d'avion. Il produit une flamme puissante et fonctionne parfaitement sous des conditions météorologiques extrêmes. Une qualité supplémentaire est le pare-vent qui a réduit les dimensions du réchaud et l'a également rendu plus silencieux. ErgoPump, multi-outils, sac en nylon, pare-vent et réflecteur de chaleur sont inclus.

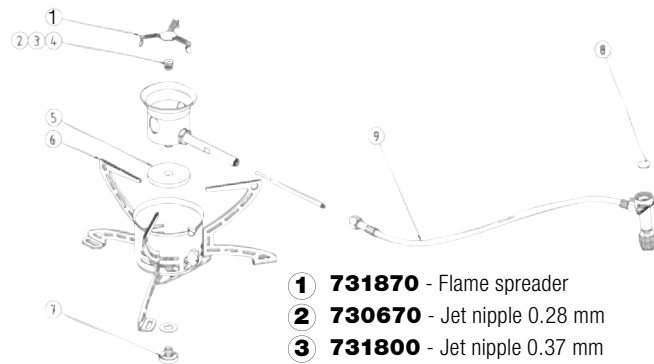

- 1 731870 - Flame spreader
  - 2 730670 - Jet nipple 0.28 mm
  - 3 731800 - Jet nipple 0.37 mm
  - 4 731790 - Jet nipple 0.45 mm
  - 5 731780 - Priming pad
  - 6 733940 - Stove body
  - 7 731940 - Brass screw
  - 8 732440 - O-ring
  - 9 721360 - Hose incl. valve
- 731860 - Multi tool  
733930 - Multi tool  
731910 - Cleaning needle  
731770 - Service & maintenance kit

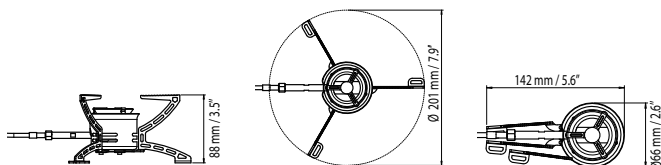

# PRIMUS Gravity™ II MF ❄️



- Powerful
- Stable
- Compact

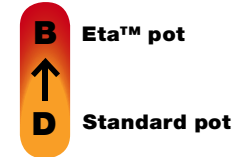

Gravity™ II MF ❄️	
🍲	365 g • 12.9 oz
🍲	263 g • 9.3 oz
🔥	3000 W • 10500 BTU/h
🕒	3 min (+ Pre-heating • Pré-chauffage • Vorwärmung 45-60 sec.)
👤	1-4 People • Personnes • Personen
🕒	70 min on 230 g • 8.1 oz gas cartridge • cartouche de gaz • Gaskartusche
328194 Gravity™ II MF	

## The ultimate stove for LP gas and liquid fuel

The Gravity MF is a powerful, stable stove. Its design makes it approx. 30% lower than other stoves. The stove has four stable, foldable legs, which means you can even use it with larger pots. Gravity II MF can be used with both gas and liquid fuels, such as white gas, gasoline/petrol, and if necessary even kerosene. The ErgoPump, multitool with integrated cleaning needle, nylon stuff sack, windscreen, and heat reflector are included.

## Le dernier modèle de réchaud à gaz et à carburants volatiles

Gravity MF est un réchaud stable et puissant et sa construction le rend environ 30% plus léger en comparaison avec d'autres réchauds. Le réchaud comporte quatre pieds stables et repliables ce qui vous permet d'utiliser de grandes casseroles. Gravity II MF peut être aussi bien utilisé avec du gaz qu'avec des combustibles liquides tels que de l'essence raffinée, de l'essence classique et en cas d'urgence du pétrole. Livré avec ErgoPump, outil multifonctions avec aiguille de nettoyage intégrée, sac en nylon, pare-vent ainsi qu'un réflecteur de chaleur.

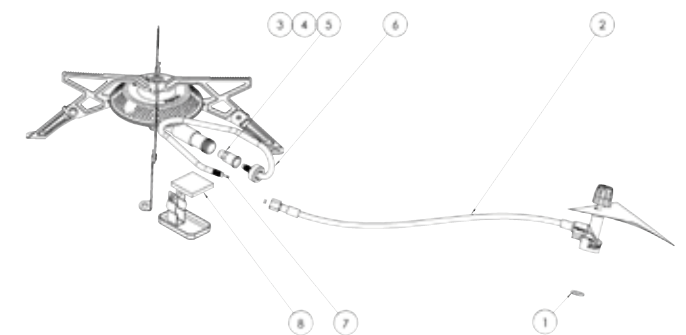

- 1 732440 - O-ring
  - 2 732910 - Hose incl. valve
  - 3 734290 - Jet nipple 0.26 mm
  - 4 734300 - Jet nipple 0.37 mm
  - 5 734310 - Jet nipple 0.42 mm
  - 6 734370 - Generator tube
  - 7 732850 - Cleaning wire
  - 8 734220 - Priming pad
- 732940 - Multi tool  
734340 - Service & maintenance kit

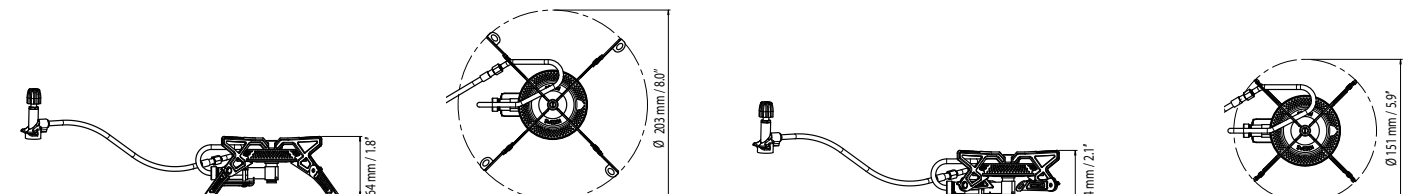

Lightweight Category











# PRIMUS Gravity™ II EF

- B** Eta™ pot
- ↑**
- D** Standard pot



- Powerful
- Stable
- Compact



Gravity™ II EF 	
 263 g • 9.3 oz	 140 x 120 x 50 mm • 5.5" x 4.7" x 2.0"
 3000 W • 10500 BTU/h	 Piezoelectric • Piézoélectrique • Piezozündung
 3 min	 1-4 People • Personnes • Personen
 70 min on 230 g • 8.1 oz gas cartridge • cartouche de gaz • Gaskartusche	
<b>327993</b> Gravity™ II EF	

## Stable and simple gas stove

This is the stove for people who want a stable, small stove but still appreciate the simplicity of gas. Thanks to the preheating coil, the stove can also be used in low temperatures. The stove has four stable, foldable legs, which means you can even use it with larger pots. The Gravity II EF comes with a windscreen, heat reflector, and nylon stuff sack.

## Réchaud à gaz stable et simple

Ce réchaud est pour vous qui souhaitez posséder un petit réchaud stable tout en appréciant la simplicité du gaz. Grâce au tube de préchauffage, le réchaud peut même être utilisé en cas de basses températures. Le réchaud comporte quatre pieds stables et pliables ce qui vous permet d'utiliser de grandes casseroles. Gravity II EF est livré avec pare-vent, réflecteur de chaleur et un sac en nylon.

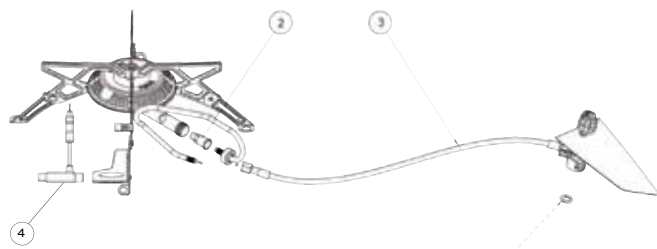



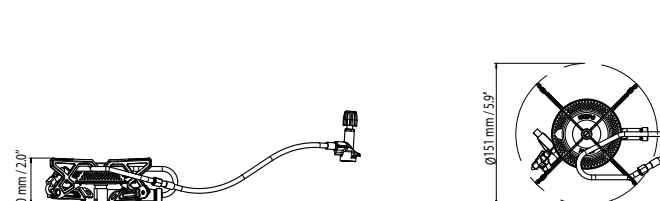
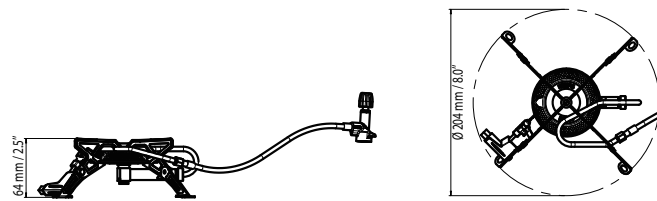





- 1 732440** - O-ring
- 2 734310** - Jet nipple 0.42 mm
- 3 732910** - Hose incl. valve
- 4 734580** - Piezo igniter



# PRIMUS ExpressSpider™



- Stable
- Compact
- Lightweight

ExpressSpider™ 	
 198 g • 7 oz	 120 x 85 x 55 mm • 4.7" x 3.3" x 2.2"
 2000 W • 7150 BTU/h	 Manual • Manuel • Manuell extern
 4.5 min	 1-4 People • Personnes • Personen
 119 min on 230 g • 8.1 oz gas cartridge • cartouche de gaz • Gaskartusche	
<b>328484</b> ExpressSpider™ - without piezo ignition	

## ExpressSpider – A sturdy alternative to top-mounted gas stoves

The ExpressSpider is one of the lightest hose-mounted gas stoves available. As its name indicates, it uses the same technology as our ExpressStove top-mounted gas stove. And it lives up to its name by being a really lightweight stove that's also extremely stable and durable, thanks to its well-planned construction. Comes with a heat reflector and nylon stuff sack.

## ExpressSpider – Une alternative stable aux réchauds à gaz montés sur cartouche

L'ExpressSpider est l'un des réchauds à gaz montés sur flexible les plus légers et, comme son nom le laisse entendre, il est basé sur la même technologie que notre réchaud à gaz monté sur cartouche : l'ExpressStove. Tout comme son prédécesseur, c'est un vrai réchaud léger et grâce à son design bien pensé il est aussi extrêmement stable et robuste. Le réchaud est livré avec un réflecteur de chaleur et un sac en nylon.

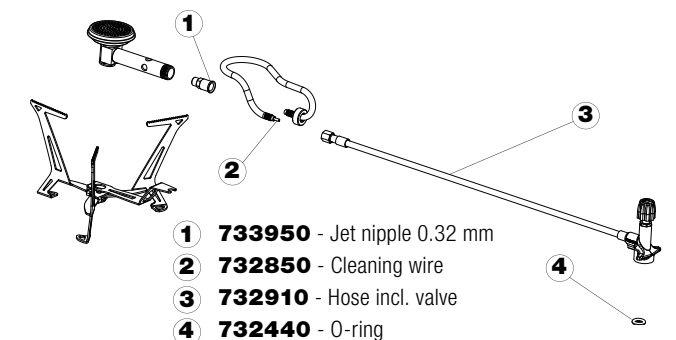

- 1 733950** - Jet nipple 0.32 mm
- 2 732850** - Cleaning wire
- 3 732910** - Hose incl. valve
- 4 732440** - O-ring

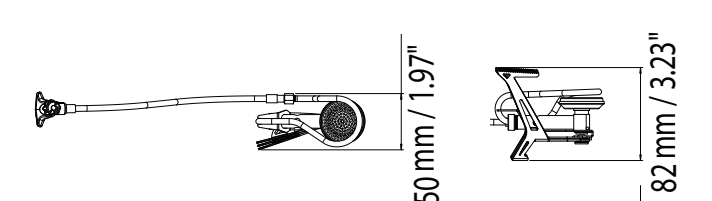
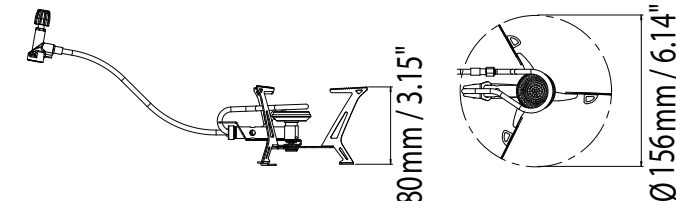









# PRIMUS ExpressStove™



- **Lightweight**
- **Stable**
- **Compact**

- A** Eta™ pot
- ↑**
- C** Standard pot

ExpressStove™ 	
 82 g • 2.9 oz 96 g • 3.3 oz ⚡ 124 g • 4.4 oz (Duo) 138 g • 4.7 oz (Duo) ⚡	 87 x 40 x 83 mm • 3.4" x 1.6" x 3.3"
 2600 W • 8900 BTU/h	 Manual • Manuel • Manuell extern Piezoelectric • Piézoélectrique • Piezozündung
 3.15 min	 1-2 People • Personnes • Personen
 85 min on 230 g • 8.1 oz gas cartridge • cartouche de gaz	
<b>321474</b> ExpressStove™ - without piezo ignition (blister pack) <b>321473</b> ExpressStove™ - with piezo ignition (blister pack) ⚡	

## Minimal stove with maximal durability

The ExpressStove has a unique combination of low weight and durability. The fact that it can handle really large pots at a low weight of just 82 grams (2.9 oz) is excellent proof of the stove's capacity. A natural choice for people who need a durable stove in the outdoors. The version with a Duo valve fits most gas cartridges with a valve on the market. The perfect stove for the global traveler. The ExpressStove is also available with the standard threaded connection. Comes with a nylon storage bag. Available with or without EasyTrigger™ piezo igniter.

## Un réchaud minimal avec une endurance maximale

Le réchaud Express est une combinaison unique d'un poids léger et d'une résistance aux chocs. Il peut supporter de larges casseroles malgré un poids léger de 82 grammes, ce qui constitue une preuve excellente de sa capacité. Un choix évident pour celui qui a besoin d'un réchaud résistant aux chocs en pleine nature. La variante avec valve Duo convient à la plupart des cartouches de gaz à valve du marché. Un réchaud parfait pour ceux qui voyagent à travers le monde. ExpressStove existe également avec un raccord fileté classique. Livré avec un sac de rangement en nylon et existe avec ou sans allumeur piézo, EasyTrigger.

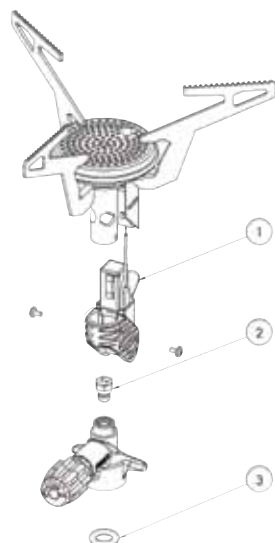
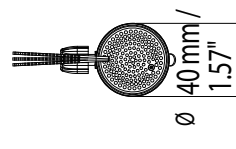
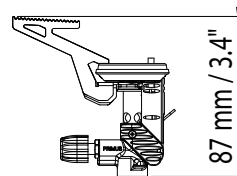
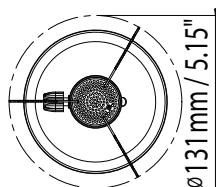
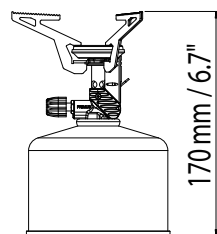

- 1 732110** - Piezo igniter for 321483 & 321443
- 2 734350** - Jet nipple 0.32 mm
- 3 732440** - O-ring









# PRIMUS TiLite™



- A** Eta™ pot
- ↑**
- D** Standard pot

- **High quality titanium**
- **Super lightweight**
- **High precision**



TiLite™ 	
 227 g • 8 oz	 Ø 120 x 95 mm • Ø 4.7" x 3.7"
 4000 W • 13500 BTU/h	 Piezoelectric • Piézoélectrique
 4 min	 1-2 People • Personnes
 45 min on 230 g • 8.1 oz gas cartridge • cartouche de gaz	
<b>324680</b> TiLite™	

## Primus TiLite™ – a little outdoor masterpiece

Extremely lightweight and compact, the TiLite consists of a stove and a saucepan. It's ideal for outdoor adventures that require minimum weight and packing volume. The TiLite is a handmade masterpiece for connoisseurs: each piece is assembled with maximum precision, giving the stove a feeling of top quality and a useful life that's sure to last as long as its owner. The stove and saucepan are made of lightweight, sturdy and rust-free titanium that's easy to clean. The 0.9 litre saucepan has folding handles. The saucepan and stove weigh just 227 g in total. The set, which has an integrated piezo igniter, can boil a TiLite saucepan filled with water in 4 minutes. Despite its compact size, the saucepan can hold a 230 gram gas cartridge.

## Primus TiLite™ – un petit chef-d'œuvre en pleine nature

Le TiLite extrêmement léger et compact comprend un réchaud et une casserole et convient aux aventures de plein air qui exigent un poids et un encombrement minimaux. TiLite est un chef-d'œuvre fabriqué à la main pour les fins connaisseurs, toutes les pièces sont ajustées avec une précision maximale, pour un réchaud de qualité supérieure et une durée de vie égale à celle de son propriétaire. Le réchaud et la casserole sont fabriqués dans un matériau léger, inoxydable et robuste : le titane ; ils sont aussi faciles à nettoyer. La casserole de 0,9 litres comporte une poignée rabattable et pèse seulement 227 g, réchaud inclus. Le kit, qui comprend un allumeur piézo, permet de faire bouillir une casserole d'eau en 4 minutes. Malgré sa taille compacte, la casserole peut aussi contenir une cartouche de gaz de 230 grammes.

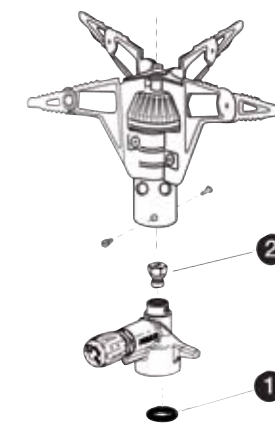

- 1 732440** - O-ring
- 2 734660** - Jet nipple 0.39 mm

# PRIMUS MicronStove™ Ti ☀



**A** Eta™ pot  
**↑**  
**C** Standard pot



MicronStove™ Ti ☀	
69 g • 2.4 oz	66 x 42 x 66 mm • 2.6" x 1.7" x 2.6"
2400 W • 8200 BTU/h	Manual • Manuel • Manuell extern Piezoelectric
4 min	1-2 People • Personnes
85 min on 230 g • 8.1 oz gas cartridge • cartouche de gaz	
321386 MicronStove™ Ti - without piezo ignition	

- Super lightweight Titanium
- Only 69 gram (2.4 oz)
- Super compact
- Wind stable

## Super lightweight stove with wind stability

We have produced a lighter MicronStove for people who make every gram in their pack count. At only 69 grams (2.4 oz) without piezo igniter, our MicronStove Ti is one of the lightest stoves in the world. To achieve this low weight, the stove is made primarily of titanium and aluminum. It comes with a nylon storage bag. Available with or without EasyTrigger™ piezo ignition.

## Réchaud au poids extrêmement léger et stable au vent

Pour ceux qui chassent les grammes en trop du paquetage, nous avons élaboré un réchaud Micron plus léger. Le réchaud ne pèse que 69 grammes sans allumeur piezo-électrique. Cela rend le réchaud Micron Ti l'un des plus légers du monde. Pour atteindre ce poids léger le réchaud est fabriqué principalement en titane et aluminium. Le réchaud est livré avec un sac de rangement en nylon et existe avec ou sans allumeur piezo, EasyTrigger™.

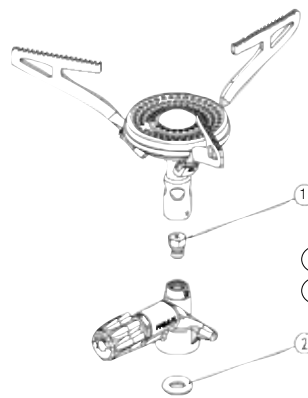
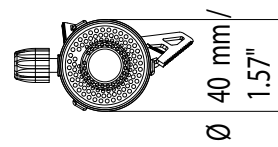
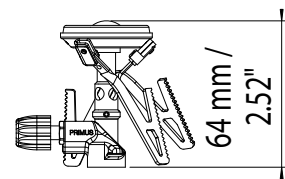
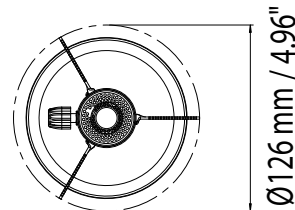
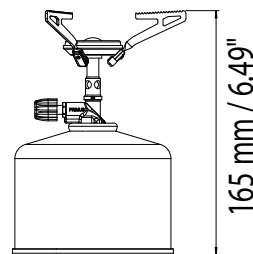

- ① 732060 - Jet nipple 0.30 mm
- ② 732440 - O-ring
- 732110 - Piezo igniter for 321389

# PRIMUS ClassicTrail™ ☀



**B** Eta™ pot  
**↑**  
**D** Standard pot



• Top Seller

ClassicTrail™ ☀	
227 g • 8 oz	125 x 125 x 55 mm • 4.9" x 4.9" x 2.2"
2800 W • 10000 BTU/h	Manual • Manuel
3 min	1-3 People • Personnes
224383 Classic Trail™	

Classic Trail is a simple, durable and classic outdoor stove for those who wish to enjoy good food in the great outdoors. A robust design and a great value. The crosswise pot support acts as a built-in windscreen that makes cooking both fast and reliable. If you don't want to think about matches, you can equip your ClassicTrail with a practical piezo igniter. Comes with a nylon bag.

Le Classic Trail est un réchaud de plein air simple, durable et classique, conçu pour ceux et celles qui souhaitent goûter les plaisirs de la bonne chair en pleine nature. Conception robuste et valeur sûre. Le support en croix accueille vos casseroles, agit comme un pare-vent intégré, vous permet de cuisiner plus rapidement et de façon plus fiable. Si vous ne tenez pas à vous encombrer d'allumettes, le ClassicTrail peut être équipé d'un allumeur piézoélectrique très pratique. Livré avec un filet en nylon.

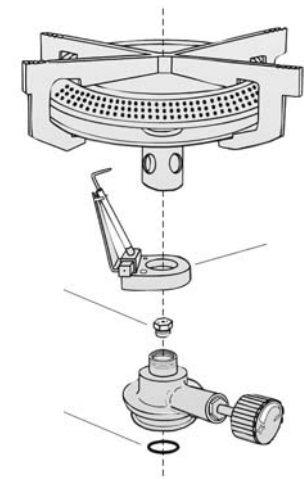

- ① 732440 - O-ring
- ② 731840 - Jet nipple 0.37 mm
- ③ 720120 - Piezo Igniter

# PRIMUS Twin Stove ☀



		☀	
	1.8 kg • 4 lbs		530 x 230 x 105 mm • 21" x 9.1" x 4.1"
	2 x 2800 W • 2 x 10000 BTU/h		Manual • Manuel
	3 min		1-10 People • Personnes
<b>229094</b> Twin Stove			

Family Outdoor

## A perfect stove when cooking for a lot of people outdoors

This stove can be used on any number of occasions, e.g. family camping, canoe trips, or cooking in the backyard. Two large burners with pot supports make the stove stable for boiling and frying. The legs fold to make the stove easy to stow. The stove is powered by the PRIMUS PowerGas 2207, 2206 or 2202 LP gas cartridges.

## Un réchaud parfait pour la préparation de repas pour plusieurs personnes en pleine nature

Le réchaud peut être utilisé à plusieurs occasions, comme par exemple le camping en famille, une excursion en canoë ou bien la préparation du repas dans le jardin. Deux brûleurs larges avec supports pour récipients rendent le réchaud stable à la fois pour la cuisson ou les grillades. Des pieds rabattables permettent d'entreposer facilement le réchaud. Le réchaud fonctionne avec des cartouches de butane de 2207, 2206 ou de 2202 Primus.

### Spare parts:

- 731840** – Jet nipple
- 732440** – O-ring (for 229094)
- 733790** – O-ring (for 229044)

# PRIMUS Atle Stove ❄



Uses propane canister #200593

- *Stainless steel*
- *12000 BTU burners*
- *Flexible hose connector for 1 lbs. propane canister*
- *Integrated handle*
- *Piezo Ignitor*

		❄	
<b>Atle Stove</b>			
	5.2 kg • 11.5 lbs		550 x 300 x 95 mm • 21.5" x 11.8" x 3.8"
	2 x 3360 W • 2 x 12000 BTU/h		Piezoelectric • Piézoélectrique
	3 min		1-10 People • Personnes
<b>329985</b> Atle Stove with 1" US propane connection			

## For demanding outdoor chefs

An appreciated and popular classic! The stove can easily be folded and is equipped with a lock and carrying handle, which makes it easy to carry along. There is room for large pots and frying pans on two separate adjustable flames. It has an effective windshield. Comes with a premium flexible hose for use with 1 lbs. propane canisters.

## Pour les cuisiniers de plein air exigeants

Un classique apprécié et populaire! Le réchaud se replie facilement, il est équipé d'un système de verrouillage et de poignées de transport ce qui le rend facile à emporter. Il y a suffisamment de place au-dessus des deux flammes séparées et réglables pour les casseroles larges et les poêles. Protection pare-vent efficace. Il est livré avec flexible et embout pour les bouteilles de butane rechargeables Primus.

### Spare parts:

- 734160** - Jet nipple
- 734175** - Hose with valve, 1" US propane connection for 329985, 320485 and 320585



# PRIMUS Atle Stove & BBQ ❄️

- Stainless steel
- Piezo ignition
- Propane
- Integrated handle
- Flexible hose for 1 lbs. propane canister



Uses propane canister #200593

Atle Stove ❄️	
6.2 kg • 13.2 lbs (3204)	590 x 320 x 135 mm • 23.5" x 12.6" x 5.3"
1 x 3360 W • 1 x 12000 BTU/h (Stove) 1 x 2850 W • 1 x 9700 BTU/h (BBQ)	Piezoelectric • Piézoélectrique
3 min	1-10 People • Personnes
<b>320485</b> Atle Stove & BBQ with 1" US propane connection	

This stove is the perfect camper grill with 12,000 BTU burner and also a BBQ grill burner with stainless steel drip tray. The removable grill tray has a non-stick coating, which makes it easy to clean. Comes with a flexible hose for a 1 lb. propane tank.

Le réchaud parfait pour le campeur avec un bruleur de 3360 W, il est aussi équipé d'un grill bruleur avec tiroir - égouttoir en dessous en acier inoxydable. La grille démontable est recouverte d'une couche non-adhésive qui la rend facile à nettoyer.

**Spare parts:**

- 734160** - Jet nipple
- 734175** - Hose with valve, 1" US propane connection for 329985, 320485 and 320585



# PRIMUS Atle Dual Stove & BBQ ❄️



- Stainless steel
- Piezo ignition
- Propane
- Integrated handle
- Flexible hose for 1 lbs. propane canister



Uses propane canister #200593

Atle Stove ❄️	
6.2 kg • 13.2 lbs (3204)	590 x 320 x 135 mm • 23.5" x 12.6" x 5.3"
2 x 3360W - 2 x 12000 BTU/h (stove) 1 x 2850W - 1 x 8000 BTU/h (BBQ)	Piezoelectric • Piézoélectrique
3 min	1-10 People • Personnes
<b>320585</b> Atle Stove & BBQ with 1" US propane connection	

This stove is the perfect family camping grill and stove with 2 12,000 BTU stoves burners and also a convenient BBQ grill with a stainless steel drip tray. The removable grill tray has a non-stick coating, which makes it easy to clean. Comes with a flexible hose for a 1 lb. propane cylinder.

Le réchaud parfait pour le campeur avec un bruleur de 3360 W, il est aussi équipé d'un grill bruleur avec tiroir - égouttoir en dessous en acier inoxydable. La grille démontable est recouverte d'une couche non-adhésive qui la rend facile à nettoyer.

**Spare parts:**

- 734160** - Jet nipple
- 734175** - Hose with valve, 1" US propane connection for 329985, 320485 and 320585



# PRIMUS Vidar BBQ



## THE ULTIMATE PORTABLE BBQ.

Whether you're on the beach, at a campsite or in the woods, you can enjoy a quick and easy barbecue with the new PRIMUS Vidar BBQ. For over 100 years we've been a part of people's adventures, both big and small. And their eating experiences too!

Visit [www.primuscamping.com](http://www.primuscamping.com) to find out more about our products and what we do for the environment.



# PRIMUS Vidar BBQ ☀



Vidar BBQ ☀	
4.5 kg • 10 lbs	403 x 415 x 90 mm • 15.9" x 16.3" x 3.5"
2500 W • 9000 BTU/h	Piezoelectric • Piézoélectrique
5 min	1-4 People • Personnes
<b>440010</b> Vidar BBQ	

### Have a BBQ anytime, anywhere!

Why put up with ordinary disposable BBQ grills that are difficult to light, don't burn long enough, don't heat evenly and aren't environmentally friendly? According to a recent study, gas grills release only one-third as much carbon dioxide into the atmosphere compared to charcoal grills\*. The Primus Vidar BBQ is a portable BBQ grill that's easy to use on a balcony, patio, beach or campground. With its non-stick coated grill surface measuring 28 x 35 cm (11" x 13.7"), there is enough room to cook for up to four people at a time. The highly efficient burner makes the BBQ grill ready to use in just a few minutes. The BBQ grill is supplied with an integrated piezo igniter for simple, safe use. The Vidar BBQ Grill is used with the Primus 2208 (Cassette gas), which makes it economical to use.

### Grillez où vous voulez!

Pourquoi se satisfaire de grills jetables qui sont difficiles à allumer, ne brûlent pas assez longtemps, donnent une chaleur irrégulière et qui sont en plus néfastes à l'environnement? Selon une nouvelle étude, les grills à gaz ne représentent qu'un tiers des effets du gaz carbonique sur l'environnement par rapport aux grills à charbon\*. Primus Vidar BBQ est un grill portatif qui est simple à utiliser sur le balcon, la terrasse, la plage ou en camping. Avec une grille à la surface anti-adhérente de 28 x 35 cm, vous pouvez cuire pour jusqu'à quatre personnes en même temps. Le brûleur hautement efficace permet au grill d'être utilisable après seulement quelques minutes. Le grill est livré avec allumeur-piézo intégré pour une manipulation simple et sûre. Le Vidar BBQ s'utilise avec les cartouches de gaz Primus 2208 (Cassette gas), ce qui réduit les coûts de fonctionnement.

Uses cassette gas #220893



**Spare parts:**  
**734760** – Grill grate  
**734770** – Piezo ignitor

# PRIMUS Camping Fuels



## Propane camping fuel cylinders need to perform - period.

Consistent, high-quality performance is exactly what you'll get when using a Primus camping fuel cylinder whether its for cooking, grilling or heating. The fuel cylinder meets or exceeds industry regulations for quality and is manufactured in facilities that have won awards for safety practices and regulations.

- *Made in the U.S.A.*
- *Threads adapt to all manufacturer's lanterns & portable gas grills*
- *Contains 1 lb. Propane*

### PRIMUS Propane Fuel

Works with Coleman® and other appliances as well as with Primus Propane products. Coleman® is a registered trademark of The Coleman Company, Inc.

**Part number:**  
**200593** - 16.4 oz (1 lb.) Propane Tank

**Shipping Specifications:**  
 Units per Case: 12  
 Cases per Layer: 10  
 Layers per Pallet: 8  
 Units per Pallet: 960  
 Pallet weight: 2,080  
 Pallet Dimensions: 48" x 40" x 85"  
 Carton Dimensions: 16" x 12" x 8.25"

### PRIMUS Fuel Bottle

Ultra light fuel bottle of seamless extruded aluminium and lacquered inside to give the bottle better protection. The connection threads are standard and suitable for OmniFuel, MultiFuel, VariFuel, Gravity VF & MF and EtaPower MF as well as most common pump stoves that burn liquid fuels.

**Part number:**  
**734120** - 0.35 l. Dimensions: Ø 65 x 150 mm • 2.6" x 5.9". Volume: 300 ml. Weight: 92 g • 3.2 oz.  
**721950** - 0.6 l. Dimensions: Ø 75 x 200 mm • 2.9" x 7.9". Volume: 530 ml. Weight: 144 g • 5.1 oz.  
**721960** - 1.0 l. Dimensions: Ø 80 x 250 mm • 3.1" x 9.8". Volume: 850 ml. Weight: 213 g • 7.5 oz.  
**732530** - 1.5 l. Dimensions: Ø 88 x 310 mm • 3.5" x 12.2". Volume: 1335 ml. Weight: 279 g • 9.8 oz.

#### U.S. Only

### PRIMUS Bouteille de combustible

Ultra-légère en aluminium extrudé sans soudure et l'intérieur laqué pour donner à la bouteille une meilleure protection. Les vissages standards s'adaptent aux réchauds OmniFuel, MultiFuel, VariFuel, Gravity VF & MF et EtaPower MF et à la plupart des réchauds à pompe classiques utilisant des combustibles liquides.

**N° réf. de l'article:**  
**734121** - 0,35 l. Dimensions: Ø 65 x 150 mm. Capacité: 300 ml. Poids: 92 g.  
**721951** - 0,6 l. Dimensions: Ø 75 x 200 mm. Capacité: 530 ml. Poids: 144 g.  
**721961** - 1,0 l. Dimensions: Ø 80 x 250 mm. Capacité: 850 ml. Poids: 213 g.  
**732531** - 1,5 l. Dimensions: Ø 88 x 310 mm. Capacité: 1335 ml. Poids: 279 g.

#### Canada Only



For Canada only

### PRIMUS PowerFuel

Contains naphtha with added corrosion protection.

**Part number:**  
**220994** - 1 l. Dimensions: Ø 83 x 240 mm • 3.3" x 9.4". Volume: 1 l. Weight: 690 g • 24.3 oz.

### PRIMUS PowerFuel

Contient d'essence chimique vierge (Heptane) avec protection anti-corrosion.

**N° réf. de l'article:**  
**220994** - 1 L. Dimensions: Ø 83 x 240 mm. Capacité: 1 L. Poids: 690 g.



### PRIMUS PowerGas

Contains 100, 230 g or 450 g of Primus' gas mixture, 4 Seasons. The largest cartridge (220294) contains the equivalence of approximately 1 l of methylated spirits, sufficient to boil about 30 l of water. The cartridges are equipped with self-sealing, safety valves and internationally standard screw threads.

**Part number:**  
**220694** - 100 g • 3.5 oz. Dimensions: Ø 90 x 67 mm • 3.5" x 2.6". Gross weight: 198 g • 7 oz.  
**220794** - 230 g • 8.1 oz. Dimensions: Ø 108 x 85 mm • 4.2" x 3.3". Gross weight: 390 g • 13.7 oz.  
**220294** - 450 g • 15.9 oz. Dimensions: Ø 108 x 137 mm • 4.2" x 5.4". Gross weight: 645 g • 22.7 oz.

### PRIMUS PowerGas

Contient 100 g, 230 g ou 450 g du mélange de gaz Primus, 4 saisons. La plus grande cartouche (220294) équivaut à environ 1 l d'alcool méthylique dénaturé, suffisant pour faire bouillir environ 30 l d'eau. Réservoirs à gaz dotés de valves de sécurité à fermeture automatique. Filetage conforme aux normes internationales.

**N° réf. de l'article:**  
**220694** - 100 g. Dimensions: Ø 90 x 67 mm. Poids (brut): 198 g.  
**220794** - 230 g. Dimensions: Ø 108 x 85 mm. Poids (brut): 390 g.  
**220294** - 450 g. Dimensions: Ø 108 x 137 mm. Poids (brut): 645 g.





## How to mantle a lantern



Use outdoors only! Slip the mantle over the burner. The large hole should be over the entire perforated part of the burner. The little hole should only be over the tip of the burner.

Uniquement pour utilisation à l'extérieur! Glissez le manchon sur le brûleur. Le grand trou doit recouvrir la partie perforée du brûleur. Le petit ne doit en recouvrir que l'extrémité.

Nur im Freien verwenden! Stülpen Sie den Glühstrumpf über den Brenner. Die große Öffnung wird über den Brenner in die Einkerbung gezogen, die obere, kleine Öffnung über die Brennerspitze.

Endast för utomhusbruk! Trä glödstrumpan över brännaren. Observera att det stora hålet ska träs över hela den hålförsedda delen av brännaren. Det lilla hålet i glödstrumpan ska endast dras över spetsen på brännaren.



Warning! Do not switch on the gas! Burn off the mantle by lighting it.

Attention! N'ouvrez pas le gaz! Laissez le manchon se consumer entièrement en l'allumant.

Achtung! Das Ventilrad muss fest geschlossen sein! Zünden Sie den Glühstrumpf mit einem Feuerzeug an.

Varning! Skruva inte på gasen! Bränn av glödstrumpan genom att antända den.



Let it burn until there is only a white "skeleton" left.

Laissez-le se consumer jusqu'à ce qu'il ne reste plus qu'un "résidu" blanc.

Lassen Sie den Glühstrumpf ausbrennen, bis nur noch ein „Skelett“ übrig bleibt.

Låt den brinna/glöda tills ett vitt "ägg" har bildats.



Switch on the gas and ignite the lantern. Run it in full effect for about 30 seconds. Put the glass back in position. The lantern is now ready for use.

Allumez-le en faisant s'échapper le gaz à plein débit et laissez-le brûler pendant environ 30 secondes. Remettez le verre. La lampe est prête à fonctionner.

Betreiben Sie die Leuchte für 30 Sekunden mit voller Leistung. Montieren Sie das Glas wieder an seiner ursprünglichen Position. Die Leuchte ist nun betriebsbereit.







Antänd med gas på full effekt och låt den brinna i ca 30 sekunder. Sätt på glaset. Lyktan är nu klar att användas.

# PRIMUS MicronLantern™



- Durable
- Lightweight
- Compact
- Super silent
- 235/360 Lumens



MicronLantern™ 			
	124 g • 4.4 oz 198 g • 7 oz		4-36 h
	235 lumens 360 lumens		300 W • 1100 BTU/h
	Piezoelectric • Piézoélectrique		
221383 MicronLantern™ - with piezo ignition (steel mesh) ⚡			
221363 MicronLantern™ - with piezo ignition (glass) ⚡			

### MicronLantern - A brighter future

The MicronLantern is a compact, lightweight and durable lantern that provides light and warmth when you need small dimensions, low weight and durability. It's available in two versions: with a stainless steel mesh or in frosted glass. The stainless mesh is more durable, of course, whereas the glass version provides a more powerful light. Brightness is infinitely adjustable, up to 235 lumens on the steel mesh version and 360 lumens on the glass version. The EasyTrigger™ ignition system allows for quick and easy lighting. The patented burner ensures that the lantern is virtually silent and uses little gas. The steel mesh lantern is supplied with a nylon stuff sack, and the glass version comes in a sturdy plastic case.

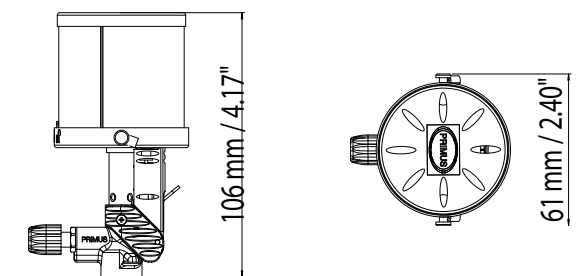

### MicronLantern - Un avenir plus clair

La lanterne Micron est compacte, légère et durable. Elle apporte lumière et chaleur à ceux pour qui des dimensions réduites, un faible poids et une extrême longévité sont des critères incontournables. Elle est disponible dans deux variantes, soit avec une grille inoxydable soit avec un verre dépoli. La grille inoxydable résiste naturellement aux chocs tandis que le modèle avec verre apporte une lumière plus puissante. La puissance de la lumière est réglable jusqu'à 235 lumens pour le modèle avec grille et 360 lumens pour le modèle avec verre. Le système d'allumage Easytrigger permet un allumage rapide et simple. Le brûleur breveté garantit le silence théorique de la lanterne ainsi qu'une consommation réduite de gaz. La lanterne avec grille est livrée avec un sac en nylon tandis que la variante avec verre est livrée dans une boîte en plastique résistante aux chocs.

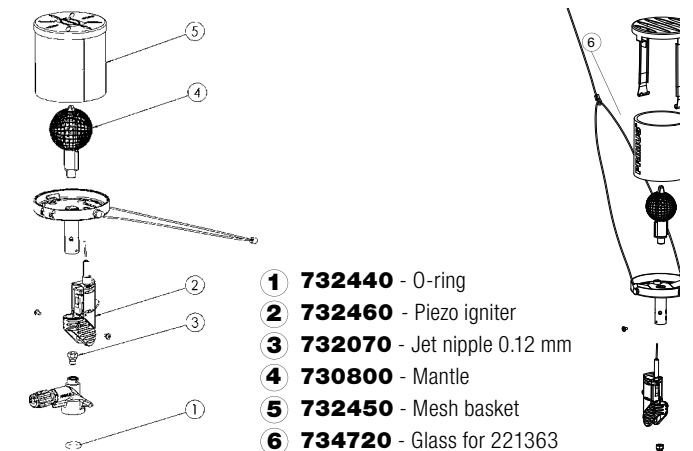

- 1 732440 - O-ring
- 2 732460 - Piezo igniter
- 3 732070 - Jet nipple 0.12 mm
- 4 730800 - Mantle
- 5 732450 - Mesh basket
- 6 734720 - Glass for 221363

Lightweight Category









# PRIMUS EasyLight™



- Durable plastic case



- Super silent
- Automatic ignition
- 490 Lumens

EasyLight™ Duo 			
 192 g • 6.8 oz ⚡	 4-36 h	 83 x 83 x 127 mm • 3.3" x 3.3" x 5"	
 490 lumens	 300 W • 1100 BTU/h	 Piezoelectric • Piézo-électrique	
224583 EasyLight™ - with piezo ignition ⚡			



Duo Category

## Light and warmth – anywhere

The EasyLight spreads light and warmth and takes up no more space than a medium-sized orange in your backpack. The lantern is equipped with a piezo igniter and a patented, almost noiseless burner and has a continuously adjustable brightness corresponding to a maximum of 490 lumens. The version with a Duo valve fits most gas cartridges with a valve on the market. The perfect lantern for the global traveler. The EasyLight is also available with the standard threaded connection, made of corrosion and maintenance-free materials and comes in a durable plastic box.

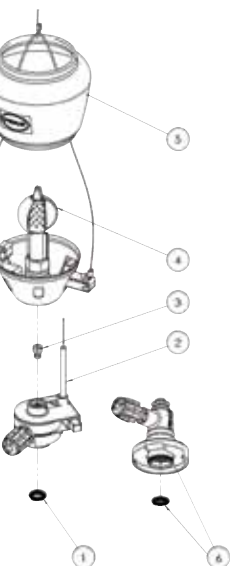
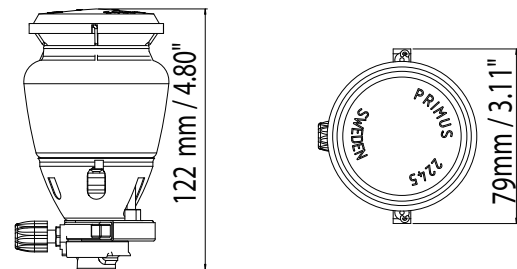

- 1 732440 - O-ring for 224583/84
- 2 730850 - Piezo igniter
- 3 732070 - Jet nipple 0.12 mm
- 4 730800 - Mantle
- 5 721490 - Glass
- 6 733790 - O-rings for 224543

## Lumière et chaleur – partout

La lanterne EasyLight répand la lumière et la chaleur partout autour d'elle et ne prend pas plus de place qu'une orange de taille moyenne dans le sac à dos. La lanterne est équipée d'un allumeur piézo, d'un brûleur breveté pratiquement silencieux et a une puissance lumineuse réglable qui correspond à un maximum de 490 Lumen. La variante avec valve Duo convient à la plupart des cartouches de gaz avec valve du marché. Une lanterne parfaite pour ceux qui voyagent à travers le monde. EasyLight, également proposée avec un raccord fileté classique, est fabriquée dans un matériau anticorrosion ne nécessitant pas d'entretien et est livrée dans une boîte en plastique résistant aux chocs.

# PRIMUS Tor Jr. & Sr. Lantern



PRIMUS Tor Sr. Lantern

- 200 W equivalent
- Adjustable level
- Piezo ignition
- Sturdy Base included









## A solid classic in a stainless steel design

The lanterns provides a quiet, adjustable light up to the equivalent of 200 W. They are easy, robust, and heats well in cold areas. With piezo ignition.

## Un classique fiable en finition inoxydable

Les lanternes offrent une lumière silencieuse et réglable équivalente à 200 W. Elles sont simples et robustes et réchauffent bien dans les espaces frais. Livrées avec ou sans allumeur-piézo.

**Spare parts:**  
811006 - Frosted lantern glass Sr  
800901 - Mantle Sr

Tor Sr. Lantern 			
 740 g • 26 oz (2162/69)	 Ø 133 x 200 mm • Ø 5.2" x 7.8"	 1400 lumens	 5-25 h
 200 W • 685 BTU/h	 Piezoelectric • Piézoélectrique		
216995 Tor Sr. Lantern with piezo ignition			



PRIMUS Tor Jr. Lantern

- 120 W equivalent
- Adjustable level
- Piezo ignition
- Sturdy Base included









## A solid classic in a stainless steel design

The lanterns provides a quiet, adjustable light up to the equivalent of 120 W. They are easy, robust, and heats well in cold areas. With piezo ignition.

## Un classique fiable en finition inoxydable

Les lanternes offrent une lumière silencieuse et réglable équivalente à 120 W. Elles sont simples et robustes et réchauffent bien dans les espaces frais. Livrées avec ou sans allumeur-piézo.

**Spare parts:**  
720630 - Frosted lantern glass Jr  
730800 - Mantle Jr

Tor Jr. Lantern 			
 390 g • 13.8 oz (2172/79)	 Ø 100 x 160 mm • Ø 3.9" x 6.3"	 330 lumens	 5-25 h
 120 W • 430 BTU/h	 Piezoelectric • Piézoélectrique		
217995 Tor Jr. Lantern with piezo ignition			

# PRIMUS Camping Lantern



- LED Technology
- Batteries included
- 3 step switch



Camping Lantern			
	9 White LEDs • Blanc • Weiße • Vita (108 000 mcd)		
	65 g • 2.3 oz - Mini 93 g • 3.3 oz - Pocket 385 • 13.6 oz		Ø 35 x 125 mm • Ø 1.4" x 4.9" -Mini Ø 47 x 145 mm • Ø 1.9" x 5.7" -Pocket Ø 85 x 210 mm • Ø 3.4" x 8.3
	4 x AAA - Mini 4 x AA - Pocket 3 x D		12 - 50 h -Mini 12 - 50 h -Pocket 50 - 180 h
	Water resistance (IPX4) • Résistance à l'eau		
<b>372000</b> Camping Lantern Mini <b>372010</b> Camping Lantern Pocket <b>372020</b> Camping Lantern			

## Portable camping lanterns for all occasions

Sturdy camping lanterns in three sizes which provide excellent lighting for both cooking, map-reading and socializing. The nine LEDs run on 4 AAA-size batteries ( 372000), 4 AA-size batteries (372010) or 3 D-size batteries (372020). A built-in reflector helps to spread the light. Each lantern has three different brightness settings and comes equipped with a rubber-coated base for extra impact resistance. The large lantern (372020) also has a flashing light setting.

## La lanterne de camping portable pour toutes les situations

Une lanterne de camping robuste en trois tailles différentes qui apporte une bonne lumière permettant à la fois de cuisiner, de lire les cartes et de se réunir entre amis. Les neuf diodes DEL lumineuses fonctionnent avec 4 piles AAA (modèle 372000), 4 piles AA (modèle 372010) ou 3 piles D (modèle 372020), et la lumière est renvoyée au moyen d'un réflecteur intégré. Les trois lanternes ont trois niveaux lumineux et sont équipées d'un fond en caoutchouc pour une meilleure résistance aux chocs. La grande lanterne (372020) comporte également un niveau clignotant.

# PRIMUS "Solar" Camping Lantern



- LED Technology
- Batteries included



Solar Camping Lantern			
	5 White LEDs • Blanc • Weiße • Vita (60 000 mcd)		
	385 • 13.6 oz		Ø 85 x 210 mm • Ø 3.4" x 8.3
	3 x D		100 - 180 h
	Water resistance (IPX4) • Résistance à l'eau		
<b>372030</b> Solar Camping Lantern			

## Solar Camping Lantern – recycled sunshine

Our popular Camping Lantern is now available in a new version – with rechargeable batteries that use a solar panel on the top of the lantern. This makes the lantern both environmentally friendly and economical to use. Of course you can also use regular D-size batteries if you didn't have a chance to charge the lantern.

## Lanterne de camping solaire – le soleil recyclé

Notre lanterne de camping populaire est maintenant disponible dans une nouvelle version avec des batteries rechargeables à l'aide du panneau solaire sur le dessus, pour une lanterne écologique et économique à l'emploi. Bien sûr, vous pouvez utiliser des piles D habituelles au cas où la lanterne ne pourrait être rechargée.

# PRIMUS Lantern Accessories



720182



721490



734720



720630



811006

**Lantern Glass**

Glass for Classic Moonlite (324083), Classic Trekkite (323083), EasyLight (2245) and MicronLantern (221363).

**Part number:**

- 720182 – Classic Moonlite
- 721490 – Classic Trekkite and EasyLight
- 734720 – MicronLantern
- 811006 – Tor Sr.
- 720630 – Tor Jr.

**Verres de lampe**

Verres pour lampes Classic Moonlite (324083), Classic Trekkite (323083), EasyLight (2245) et MicronLantern (221363).

**N° réf. de l'article:**

- 720182 – Classic Moonlite
- 721490 – Classic Trekkite and EasyLight
- 734720 – MicronLantern
- 811006 – Tor Sr.
- 720630 – Tor Jr.

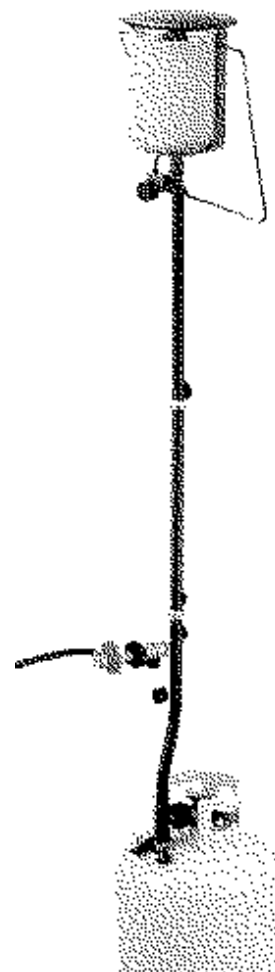

**Propane Distribution Stand**

45 inch overall length  
3 sections - 15 inch collapsed  
Able to hook up 3 appliances

**Part number:**  
734780

# PRIMUS PrimeLite™ Race



- Powerful
- Reflective strap
- Reflector housing in aluminium
- Waterproof



734570 - Electronic insert

PrimeLite™ Race			
Luxeon™ Rebel (140 lumens)	125 m • 137 yd	3-20 h	205 g • 7.2 oz
		4 AA Alk / Li / NiMh	
Waterproof (IPX7) • Étanche			
366001 PrimeLite™ Race			

## PrimeLite™ Race – for outdoor and adventures

PrimeLite Race is built around the Luxeon™ Rebel diode with a brightness of no less than 140 lumens and a range of 125 meters. The actual lamp is attached on a reflective headband and the battery pack is kept in a pocket or backpack. It runs on both alkaline and lithium batteries as well as different kinds of rechargeable batteries. Delivered with 4 AA batteries and a light-coloured storage bag that also works as a light dampener.

## PrimeLite™ Race – pour la vie en plein air et l'aventure

PrimeLite Race est construite autour de la diode Luxeon rebel™ avec une puissance lumineuse de 140 lumens et une portée de 125 mètres. La lampe elle-même est accrochée à un bandeau comportant des réflecteurs et le boîtier des piles est placé dans une poche ou dans le sac à dos. Elle peut être alimentée à la fois par des piles alcalines ou au lithium ainsi que par différents types de pile rechargeable. Livrée avec 4 piles AA et un sac de rangement clair qui adoucit la lumière pour un usage général.



**Mantle (pack of 3)**

Thorium free mantles for Primus lanterns. (Micron, EasyLite or Tor Jr.)

**Part number: 730800**

**Manchons à incandescence (par 3)**

Manchons à incandescence sans thorium pour lampes Primus. (Micron, EasyLite or Tor Jr.)

**N° réf. de l'article: 730800**



**Mantle (pack of 3)**

Thorium free mantles for Primus lanterns. (Tor Sr.)

**Part number: 800901**

**Manchons à incandescence (par 3)**

Manchons à incandescence sans thorium pour lampes Primus. (Tor Sr.)

**N° réf. de l'article: 800901**

# PRIMUS PrimeLite™ Compact Adventure

- Compact
- Multi functions
- Reflective strap
- Night vision, red LEDs



PrimeLite™ Compact Adventure			
2 Red LEDs • Rouge • Rote • Röda (16000 mcd)	12 m • 13 yd	80 h	68 g • 2.4 oz
4 White LEDs • Blanc • Weiße • Vita (48000 mcd)	30 m • 33 yd	50 h	
Luxeon™ (80 lumens)	75 m • 82 yd	12 h	
50 x 66 x 32 mm • 2" x 2.6" x 1.3"		3 AAA Alk / Li / NiMh	
Waterproof (IPX7) • Étanche			
<b>364501</b> PrimeLite™ Compact Adventure			

## PrimeLite™ Compact Adventure

Primus's most versatile headlamp. Compact Adventure is equipped with red lighting to not impair night vision as well as a function warning when batteries are low. It has two red and four white light-emitting diodes as well as a powerful Luxeon™ diode. The brightness is adjustable on six levels. The reflective headband means you are visible from every direction. This model comes with 3 AAA batteries (that fit in the light bulb holder) and a storage bag that can also be used as a light dampener.

## PrimeLite™ Compact Adventure

C'est la lampe frontale pour toute personne désireuse d'obtenir un effet lumineux maximal et n'ayant pas besoin d'une lumière rouge. Elle est pourvue de quatre diodes blanches ainsi que d'une diode Luxeon™. La puissance de l'éclairage est réglable en cinq niveaux avec six diodes. Les réflecteurs intégrés au bandeau frontal vous rendent visible dans toutes les directions. Ce modèle est livré avec trois piles AAA (qui tiennent dans le boîtier de la lampe) et un sac de rangement qui peut également être utilisé pour atténuer la lumière.

# PRIMUS PrimeLite™ Compact Trekk

- Compact
- Multi functions
- Reflective strap



PrimeLite™ Compact Trekk			
6 White LEDs • Blanc • Weiße • Vita (72000 mcd)	35 m • 38 yd	40 h	68 g • 2.4 oz
Luxeon™ (80 lumens)	75 m • 82 yd	12 h	
50 x 66 x 32 mm • 2" x 2.6" x 1.3"		3 AAA Alk / Li / NiMh	
Waterproof (IPX7) • Étanche			
<b>363501</b> PrimeLite™ Compact Trekk			

## PrimeLite™ Compact Trekk

This headlamp is for anyone who wants maximum light output but doesn't need red light. It is equipped with six white light-emitting diodes as well as a powerful Luxeon™ diode. The brightness is adjustable on five levels with six diodes. The reflective headband means you are visible from every direction. This model comes with 3 AAA batteries (that fit in the light bulb holder) and a storage bag that can also be used as a light dampener.

## PrimeLite™ Compact Trekk

C'est la lampe frontale pour vous qui souhaitez un effet lumineux maximal et qui n'avez pas besoin d'une lumière rouge. Elle est pourvue de quatre diodes blanches ainsi que d'une diode Luxeon™. La puissance de l'éclairage est réglable en cinq niveaux avec six diodes. Le bandeau avec réflecteurs vous rend visible dans toutes les directions. Ce modèle est livré avec trois piles AAA (qui tiennent dans le boîtier de la lampe) et un sac de rangement qui peut également être utilisé pour atténuer la lumière.

# PRIMUS PrimeLite™ Power Eye

- High power LED
- Water resistant
- Durable
- International SOS flash



## PrimeLite™ Power Eye – for outdoors and at home

The PrimeLite Power Eye will help you to get long visibility for a long time. With LED technology from Cree®, the PrimeLite Power Eye gives off 40 lumens of light and its batteries last up to 18 hours. The headlamp is supplied with 2 AAA batteries and a storage bag that can also be used as a shade to provide general lighting.

## PrimeLite™ Power Eye – aussi bien en plein air qu' à la maison

Avec PrimeLite Power Eye, vous voyez loin et longtemps. Grâce à la technologie DEL de Cree®, PrimeLite Power Eye a une puissance d'éclairage de 40 lumens et les piles ont une longévité de 18 heures. La lampe est livrée avec 2 piles AAA ainsi qu'un sac de rangement qui peut aussi être utilisé pour atténuer la lumière générale.

PrimeLite™ Power Eye			
1 Cree® XR-C P4 (80 lumens)	86 m • 95 yd	18 h	60 g • 2.1 oz
58 x 33 x 37 mm • 2.3" x 1.3" x 1.5"		2 AAA Alk / Li / NiMh	
Water resistance (IPX4) • Résistance à l'eau			
<b>362501</b> PrimeLite™ Power Eye			



# PRIMUS PrimeLite™ Eye

- Lightweight
- Easy to use
- Water resistant
- Durable
- Available in mixed fashion colours

## PrimeLite™ Eye – for everyday use

The PrimeLite Eye is perfect to take along anywhere. Despite its light weight, it gives a powerful beam and can be used when you're working on the car, walking the dog or when the power goes out. The headlamp is supplied with 2 AAA batteries and a storage bag that can also be used as a shade to provide general lighting.

## PrimeLite™ Eye – pour une utilisation quotidienne

PrimeLite Eye est parfaite pour avoir toujours sur soi malgré son poids léger, elle donne une lumière puissante et peut être utilisée pour réparer la voiture, se promener avec le chien ou lors d'une coupure de courant. La lampe est livrée avec 2 piles AAA ainsi qu'un sac de rangement qui peut aussi être utilisé pour atténuer la lumière générale.

PrimeLite™ Eye			
1 Cree® XR-C N4 (60 lumens)	73 m • 80 yd	18 h	60 g • 2.1 oz
58 x 33 x 37 mm • 2.3" x 1.3" x 1.5"		2 AAA Alk / Li / NiMh	
Water resistance (IPX4) • Résistance à l'eau			
<b>361501</b> PrimeLite™ Eye <b>361502</b> PrimeLite™ Eye - Mixed fashion colours			



## PRIMUS PrimeLite™ Bike Clip

A bike mount that transforms your Compact Trekk, Compact Adventure, Eye, Power Eye and Race headlamp into a bike light! The mount attaches to the handlebars and the quick clip can then be used to attach and remove the light. Dimensions: 65 x 60 x 55 mm • 2.6" x 2.4" x 2.2". Weight: 40 g • 1.4 oz.

Part number: 734230

## PRIMUS PrimeLite™ Clip pour vélo

Un clip pour vélo qui transforme votre lampe frontale de type Compact Trekk, Compact Adventure, Eye, Power Eye ou Race en lumière pour vélo! Le clip s'accroche fermement au guidon ou au cadre et l'accroche rapide permet ensuite d'installer ou de retirer la lampe. Dimensions: 65 x 60 x 55 mm. Poids: 40 g.

N°réf. de l'article: 734230

# PRIMUS PrimeLite™ Selection Guide

<b>PrimeLite™ Race</b> Page 37 	204 g • 7.2 oz	4 AA	47 x 62 x 40 mm + 90 x 70 x 28 mm • 1.8" x 2.4" x 1.6" + 3.2" x 2.2" x 1"	Waterproof IPX7	1 Luxeon™ Rebel (140 lumens)	1 Luxeon™ 25 % 1 Luxeon™ 50 % 1 Luxeon™ 100 %	70 m • 77 yd 95 m • 104 yd 125 m • 137 yd 20 h 7 h 3 h
<b>PrimeLite™ Compact Adventure</b> Page 38 	68 g • 2.4 oz	3 AAA	50 x 66 x 32 mm • 2" x 2.6" x 1.3"	Waterproof IPX7	2 red LEDs (16000 mcd) 4 white LEDs (48000 mcd) 1 Luxeon™ (80 lumens)	2 LEDs red 4 LEDs 25% 4 LEDs 100% 1 Luxeon™ 50 % 1 Luxeon™ 100 % 4 LEDs flash	12 m • 13 yd 14 m • 15 yd 30 m • 33 yd 45 m • 49 yd 75 m • 82 yd 16 m • 17 yd 80 h 100 h 50 h 36 h 12 h 120 h
<b>PrimeLite™ Compact Trekk</b> Page 38 	68 g • 2.4 oz	3 AAA	50 x 66 x 32 mm • 2" x 2.6" x 1.3"	Waterproof IPX7	6 white LEDs (72000 mcd) 1 Luxeon™ (80 lumens)	6 LEDs 25% 6 LEDs 100% 1 Luxeon™ 50 % 1 Luxeon™ 100 % 6 LEDs flash	16 m • 17 yd 35 m • 38 yd 45 m • 49 yd 75 m • 82 yd 16 m • 17 yd 80 h 40 h 36 h 12 h 100 h
<b>PrimeLite™ Power Eye</b> Page 39 	60 g • 2.1 oz	2 AAA	58 x 33 x 37 mm • 2.3" x 1.3" x 1.5"	Water resistant IPX4	1 Cree® XR-C P4 (80 lumens)	1 Cree® 33 % 1 Cree® 100 % International SOS	33 m • 36 yd 86 m • 95 yd 86 m • 95 yd 18 h 4 h 36 h
<b>PrimeLite™ Eye</b> Page 39 	60 g • 2.1 oz	2 AAA	58 x 33 x 37 mm • 2.3" x 1.3" x 1.5"	Water resistant IPX4	1 Cree® XR-C N4 (60 lumens)	1 Cree® 33 % 1 Cree® 100 % International SOS	30 m • 33 yd 73 m • 80 yd 73 m • 80 yd 18 h 4 h 36 h

## A few facts about LED

LED or Light Emitting Diode was built upon semiconductor technology from the 1960s. In a traditional glow-lamp filament bulb, the majority of energy is transformed into heat with only a little part becoming light. With an LED, the majority of energy is transformed into light, the effective power increases, and the batteries last longer. Light diodes are: energy efficient • small, light and very durable • have a long life >100,000 h • function between - 40°C and +80°C • provide the same light during its entire life • provide an even white light (best for human eyes) • no spare parts necessary.

## Facts about range and lifespan

Top manufacturers use an unofficial standard to make fair comparisons of the performance of headlamps and flashlights in terms of their range and lifespan. Here is a brief explanation of the standard.

Range: The range of a headlamp or flashlight is defined as the maximum distance at which the user still has a usable light. This is 0.25 lux, which corresponds to the light from the full moon on a clear night.

Lifespan: The lifespan is the length of time the lamp continues to provide a usable light. This might be for setting up a tent, cooking food or similar activities. The lifespan depends on which of the light's functions you use, what type of batteries you use and the condition of the batteries.

## Quelques détails sur les DEL

DEL ou diode électroluminescente est basée sur la technologie semi-conductrice des années 60. La plupart de l'énergie d'une ampoule traditionnelle se transforme en chaleur tandis que la partie plutôt petite se transforme en lumière. Par contre, une DEL transforme la majorité de son énergie en lumière, la puissance effective augmente, et les piles durent plus longtemps. Les diodes lumineuses sont: peu gourmandes en énergie • petites, légères et très résistantes • ont une durée de vie >100.000 h • fonctionnent entre - 40°C et +80°C • fournissent un éclairage constant pendant toute leur durée de vie • fournissent un éclairage uniforme et blanc (préférable pour l'oeil humain) • ne nécessitent aucune pièce de rechange

## Quelques détails sur la portée et la durée d'éclairage

Afin de pouvoir comparer la prestation des lampes frontales et des lampes de poche de manière équitable, comme par ex. la portée ou la durée d'éclairage, la plupart des fabricants utilisent un standard non-officiel. En quelques mots cela signifie :

Portée : la portée d'une lampe frontale ou de poche est définie par la distance jusqu'à laquelle l'utilisateur continue à utiliser un éclairage convenable. Cela signifie une lumière de 0,25 lux, ce qui correspond à une pleine lune dans un ciel sans nuages.

Durée d'éclairage : la durée d'éclairage est la durée pendant laquelle la lampe fournit un éclairage convenable. Par ex. un éclairage pour monter sa tente, faire à manger ou autres activités équivalentes. La durée d'éclairage dépend des fonctions de la lampe et du type de batterie qui sont utilisés, ainsi que de l'état des batteries.

# PRIMUS PrimeTorch™

<b>PrimeTorch™ 101</b>			
Luxeon™ (25 lumens)	42 m • 46 yd	15 g • 0.5 oz	1 AAA
Ø 14 x 74 mm • Ø 0.6" x 2.9"		Water resistant (IPX4) • Résistance à l'eau	
<b>371010</b> PrimeTorch™ 101			



A minimal flashlight with a powerful beam despite its small design. Comes with a neck strap, head strap and a clip.

Une lampe de poche minimaliste qui malgré sa petite taille éclaire avec une forte lumière. Livrée avec sangle tour de cou, bandeau frontal et clip.

<b>PrimeTorch™ 201</b>			
Luxeon™ (50 lumens)	48 m • 52 yd	44 g • 1.6 oz	1 AA
Ø 23 x 98 mm • Ø 0.9" x 3.9"		Water resistant (IPX4) • Résistance à l'eau	
<b>371020</b> PrimeTorch™ 201			



A powerful, small-sized flashlight with a switch in the back. Comes with a metal pocket clip and neck strap.

Une lampe de poche puissante dans un petit format avec interrupteur sur le dessus. Livrée avec crochet en métal pour la ceinture et sangle tour de cou.

<b>PrimeTorch™ 601/611</b>			
Luxeon™ (50 lumens) Luxeon™ (176 lumens)	66 m • 72 yd 78 m • 85 yd	82 g • 2.9 oz	2 AA
Ø 27 x 143 mm • Ø 1" x 5.6"		Water resistant (IPX4) • Résistance à l'eau	
<b>371030</b> PrimeTorch™ 601 <b>371040</b> PrimeTorch™ 611			



A flashlight with a tactical switch, which means the light can be turned on or off quickly. Excellent for signaling. Comes with a metal pocket clip and wrist strap.

Une lampe de poche avec ce qu'on appelle un "Tactical-switch", ce qui signifie que la lampe peut être allumée ou éteinte rapidement et qu'elle est excellente pour les signaux lumineux. Livrée avec crochet en métal pour la ceinture et sangle poignet.

# PRIMUS PrimeTorch™



A powerful flashlight from Primus, manufactured in tough airplane-grade aluminium with a Luxeon Rebel LED that produces a 176-lumen beam, with battery life of up to 1.5 hours. It also has an electronic switch at the rear with instant on/off operation and low beam, high beam and flashing function. Supplied with metal clip.

Une lampe de poche puissante de Primus fabriquée en aluminium pour avion résistant aux chocs avec une DEL Luxeon Rebel d'une puissance lumineuse de 176 lumens et des piles qui durent jusqu'à 1,5 heures. Elle comporte un interrupteur électronique sur le dessus avec fonction ON/OFF, une luminosité faible ou forte ainsi qu'une lumière clignotante. Livrée avec crochet en métal pour poche.

PrimeTorch™ 701				
	Luxeon Rebel™ (176 lumens)	78 m • 85 yd	1.5 h	2 AA
	∅ 23 x 150 mm • ∅ 0.9" x 5.9"		70 g • 2.5 oz	
	Water resistant (IPX4) • Résistance à l'eau			
371080 PrimeTorch™ 701				



A truly powerful flashlight for the professional user that comes equipped with a powerful diode and two light levels, 76 and 176 lumens. It runs on a rechargeable Ni-MH battery – a natural choice for the car, toolbox, home, or backpack. Comes with a wrist strap and charger that runs on 12 or 100–230 Volts.

Une lampe de poche réellement puissante pour les professionnels qui est équipée d'une diode puissante et de deux niveaux d'éclairage de 76, respectivement 176 lumen. Elle est alimentée par une batterie Ni-MH rechargeable – une compagne indispensable aussi bien dans la voiture, dans la boîte à outils, à la maison que dans le sac à dos. Livrée avec sangle poignet et chargeur alimenté au 12 ou 100-230 Volt.

PrimeTorch™ 801				
	Luxeon™ (176 lumens)	60 m • 66 yd 105 m • 115 yd	35 h	Rechargeable
	∅ 42 x 256 mm • ∅ 1.7" x 10.2"		202 g • 7.1 oz	
	Waterproof (IPX7) • Étanche jusqu'			
371075 PrimeTorch™ 801 with US-Connector				



# PRIMUS Bifrost H4 and H6



Bifrost H6

Maximal height: 200 cm  
Inner height: 170 cm

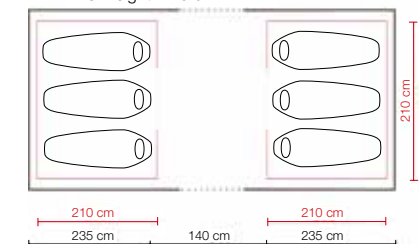

Bifrost H4

Maximal height: 190 cm  
Inner height: 165 cm

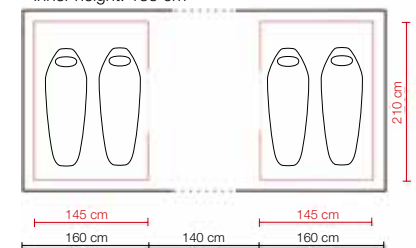

Bifrost H4 and H6			
	9.3 kg • 20.2 lbs 10.7 kg • 23.5 lbs		∅ 30 x 70 cm • ∅ 12" x 27.5" (H4) ∅ 35 x 70 cm • ∅ 14" x 27.5" (H6)
	1-4 / 1-6 People • Personnes		230 x 460 cm • 7.5 x 15.1 ft (H4) 230 x 610 cm • 7.5 x 20.0 ft (H6) Height: 190 cm • 6.2 ft (H4) Height: 200 cm • 6.6 ft (H6)
421002 Bifrost H4 422002 Bifrost H6			

## Tent with standing height

Primus Bifrost H4 and H6 are roomy tents with sleeping space for 4-6 people and a standing height to fit most people. The space creates a great feeling of having a living room between the two sleeping compartments. Ventilation openings and mosquito netting keep the moisture and mosquitoes away. Aluminium arch supports provide good stability, and colour coding makes set-up quick and convenient. A perfect tent for any number of purposes, including camping, paddling, sailing, or why not even an extra room in the backyard?

The outer tent is made of PU Coated Polyester and can handle a 3000 mm water column. The inner tent is made of Oxford Polyester and the floor fabric can handle a 7000 mm water column. The tent is equipped with storm guy lines.

The tents have privacy windows and a floor that can easily be snapped into place between the sleeping compartments. They also come with poles that allow you to raise the door for rain protection or a shady spot outside the tent.

## Tentes avec une hauteur permettant de rester debout

Les tentes Primus Bifrost H4 et H6 sont spacieuses avec un espace de couchage pour 4/6 personnes et une hauteur permettant à la plupart des personnes de rester debout. L'abside qui crée une formidable impression de salle de séjour sépare les deux espaces de couchages. Les ouvertures de ventilation et la moustiquaire empêchent l'humidité et les moustiques. Les arceaux en aluminium offrent une bonne stabilité et un code de couleurs rend le montage beaucoup plus rapide et flexible. Une tente parfaite pour différentes utilisations telles que le camping, le canoë-kayak, la voile ou bien pourquoi pas comme chambre supplémentaire dans le jardin ?

La tente extérieure est en Polyester Enduit PU et résiste à une colonne d'eau de 3000 mm. La tente intérieure est en Polyester Oxford et le tapis de sol résiste à une colonne d'eau de 7000 mm. La tente est livrée avec sangles de fixation « tempête ».





Les tentes sont pourvues d'une fenêtre protégeant contre les regards indiscrets et un tapis de sol qui peut être fermement fixé entre les espaces de couchages. Elles sont en plus livrées avec des barres de support pour la porte permettant d'obtenir un auvent contre la pluie ou le soleil à l'extérieur de la tente.

# PRIMUS Bifrost Y6

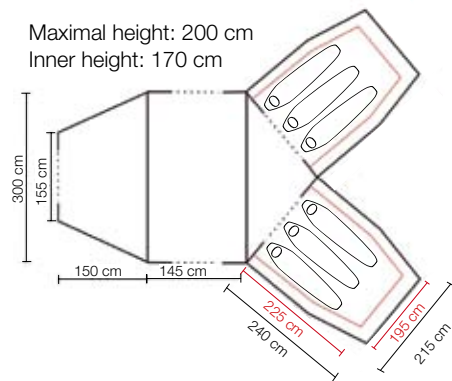

Maximal height: 200 cm  
Inner height: 170 cm



Bifrost Y6 	
 12 kg • 26.5 lbs	 Ø 40 x 70 cm • Ø 16" x 27.5"
 1-6 People • Personnes • Personen • Personer	 Unfolded • Déplié • Utfälld: 5 x 5 m • 16.4 x 16.4 ft. Height 200 cm, sleeping compartments: 195 x 225 cm • Height 6.4 ft, sleeping compartments 6.4 ft x 7.4 ft
423002 Bifrost Y6	

## Our roomiest tent

The Bifrost Y6 is our roomiest tent with two separate sleeping compartments with room for 3 people in each. The compartments are connected by a "dome" with a diameter of approx. 3 meters. The tent works well for a group of people under one roof that wants a larger space to move around in.

The outer tent is made of PU Coated Polyester and the floor fabric can handle a 3000 mm water column. The inner tent is made of Oxford Polyester and can handle a 7000 mm water column. The tent is equipped with storm guy lines.

The tents have privacy windows and a floor that can easily be snapped into place between the sleeping compartments. They also come with poles that allow you to raise the door for rain protection or a shady spot outside the tent.

## Notre tente la plus spacieuse





Bifrost Y6 est notre tente la plus spacieuse avec deux espaces de couchage séparés pouvant accueillir chacun 3 personnes. Ceux-ci sont réunis sous une "coupole" d'un diamètre d'environ 3 mètres. La tente est idéale pour un groupe de personnes qui souhaite sous le même toit avoir une surface de mouvement plus large.

La tente extérieure est en Polyester Enduit PU et résiste à une colonne d'eau de 3000 mm. La tente intérieure est en Polyester Oxford et le tapis de sol résiste à une colonne d'eau de 7000 mm. La tente est livrée avec sangles de fixation « tempête ».

Les tentes sont pourvues d'une fenêtre protégeant contre les regards indiscrets et un tapis de sol qui peut être fermement fixé entre les espaces de couchages. Elles sont en plus livrées avec des barres de support pour la porte permettant d'obtenir un auvent contre la pluie ou le soleil à l'extérieur de la tente.

# PRIMUS Shelter



Shelter	
 1.5 kg • 3.3 lbs	 Folded • Plié Ø 10 x 50 cm • Ø 4" x 20"
 1-3 People • Personnes	 Unfolded • Déplié 120 x 250 x 100 cm • 4 x 8.3 x 3.3 ft
425010 Shelter	

## Sun, wind and rain protection

This scaled-down tent can be used as protection against rain, wind, and sun. The opening is equipped with a mosquito net that can easily be tucked away at the lower edge. Pouches sewn in around the floor can be filled with sand or stone so that the tent stays put even in the wind. The tent can handle a 3000 mm water column, and the floor fabric can handle a 7000 mm water column. Comes with color-coded arch supports, storm guy lines and stakes.

## Abri pare-soleil, pare-vent et contre la pluie

Cette tente désossée peut être utilisée comme abri contre la pluie et le vent ainsi que contre le soleil. L'ouverture est équipée d'une moustiquaire qui peut être rangée facilement dans la bordure inférieure. Des "sacs" cousus fermement autour du tapis de sol peuvent être remplis de sable ou de pierres afin de stabiliser la tente même en plein vent. La tente supporte une colonne d'eau de 3000 mm et le tapis de sol une colonne d'eau de 7000 mm. Elle est livrée avec des arceaux de couleur codée, des sangles d'ancrage et des piquets de sol.

# PRIMUS Tarp

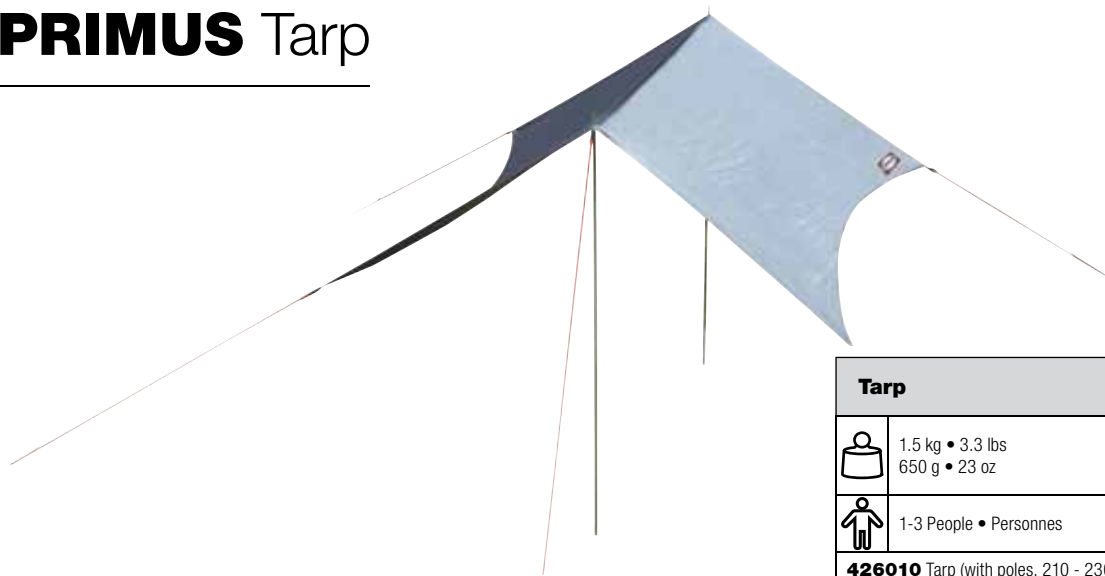

Tarp			
	1.5 kg • 3.3 lbs 650 g • 23 oz		Folded • Plié Ø 8 x 50 cm • Ø 2.8" x 17.6" Ø 8 x 25 cm • Ø 2.8" x 8.8"
	1-3 People • Personnes		Unfolded • Déplié 3 x 3 m • 9 x 9 ft
<b>426010</b> Tarp (with poles, 210 - 230 cm • 83" - 91", & ropes) <b>426020</b> Tarp LW (without poles)			

## Sun and rain protection

This combined sun and rain protection works well as a compliment to Primus's tents. It can also be used separately or between tents or likewise to increase spaces for socializing outdoors. Available in two varieties: with the tent canvas and ropes only to make every gram count or complete with ropes and poles.

## Abri pare-soleil et pluie

Cette protection combinée contre la pluie et le soleil peut être utilisée avantageusement en complément d'une tente Primus. Elle peut aussi être utilisée séparément ou entre deux tentes ou autres abris semblables afin d'augmenter l'espace convivial extérieur. Elle existe en deux variantes: avec seulement la toile de tente et les cordes d'ancrages pour celui qui chasse les grammes ou bien complète avec cordes et piquets de support.

# PRIMUS SeatRest



• **Self Inflating!**

SeatRest			
	135 g • 4.8 oz - M 155 g • 5.5 oz - L		Folded • Plié Ø 7 x 20 cm • Ø 2.8" x 8" Ø 8 x 25 cm • Ø 9.8" x 3"
	1 People • Personnes		Unfolded • Déplié 35 x 35 x 2.5 cm • 13.7" x 13.7" x 1" 36 x 22 x 4 cm • 14" x 8.8" x 1.6"
<b>734100</b> SeatRest - M <b>734090</b> SeatRest - L			

## Sit nice and warm!

The Primus self-inflating seatrest makes long days sitting in a kayak, hunting blind, or at a sporting event much more comfortable. Small and easy to carry. Made of durable 150D nylon to handle the rough stuff. Store unrolled with open valve to maintain tension. Comes with a storage bag made of nylon.

## Soyez assis au chaud et confortablement!

Les mini matelas auto-gonflables de Primus rendent les longues journées assis dans un kayak, en tour de chasse ou à un événement sportif beaucoup plus confortables. Petits et légers à transporter. Fabriqués en nylon 150D indéchirable afin de résister à une utilisation ardue. Ils doivent être rangés dépliés avec la valve ouverte afin de maintenir l'élasticité. Ils sont livrés dans un sac de transport en nylon.

# PRIMUS SleepRest



- **Self Inflating!**
- **Repair Kit Included**

SleepRest			
	1200 g • 42 oz - M 1600 g • 56 oz - L		Folded • Plié Ø 16 x 55 cm • Ø 6.3" x 21.6" - M Ø 17 x 67 cm • Ø 6.3" x 26" - L
	1 People • Personnes		Unfolded • Déplié 183 x 51 x 5 cm • 72" x 20" x 2" - M 193 x 63 x 5 cm • 76" x 25" x 2" - L
<b>734080</b> SleepRest - M <b>734070</b> SleepRest - L			

## Sleep tight!

After a day of adventure a good night sleep awaits. The Primus self-inflating sleeping mat offers both comfort and good insulation from the cold. For the best sleep comfort, the amount of air can be adjusted in the pillow and the mat individually. It can be used in a tent, trailer or even as an extra bed at home. Made of durable 150D nylon to handle the rough stuff. Store unrolled with open valve to maintain tension. Comes with straps in a storage bag made of nylon. Repair kit is also included in this product.

## Dormez bien!

Après une journée pleine d'aventures, une bonne nuit de sommeil vous attend. Avec les matelas auto-gonflables de Primus, une bonne isolation contre le froid est maintenue. Pour un meilleur confort de sommeil, la quantité d'air peut être ajustée individuellement dans l'oreiller, respectivement dans la zone de couchage. Ils peuvent être utilisés à la fois dans une tente, une caravane ou pourquoi pas comme lit d'appoint à la maison. Ils sont fabriqués en nylon 150D indéchirable afin de résister à une utilisation ardue. Ils doivent être rangés dépliés avec la valve ouverte afin de maintenir l'élasticité. Ils sont livrés avec des lanières d'emballage dans un sac de transport en nylon. Le kit de réparation est inclus dans l'emballage.



SleepRest Chair			
	300 g • 10.6 oz - M 410 g • 14.5 oz - L		
	1 People • Personnes		110 x 55 cm • 43" x 22" - M 115 x 67 cm • 45" x 26" - L
<b>734530</b> SleepRest Chair - M <b>734531</b> SleepRest Chair - L			

## PRIMUS SleepRest Chair

The ultimate accessory for your SleepRest sleeping mat. It transforms your sleeping mat into a comfortable campsite chair in less than 30 seconds!

L'ultime accessoire accompagnant le matelas SleepRest. Il transforme le matelas en une chaise confortable sur le lieu de campement en moins de 30 secondes!



# ADD SOME COLOUR TO YOUR LIFE!



Commuter Mug. Page 60.



PrimeLite Eye. Page 39.

# PRIMUS cooking equipment



• Titanium non-stick coating



### PRIMUS EtaPower™ Pot

The smallest pot in the Eta series is perfect for the solo hiker who only needs a single 1 liter pot. The lid can also be used as a frying pan. Made of hard anodized aluminum with a multi-layer titanium nonstick surface on the inside. Fits both a 230 gram gas cartridge and a stove such as the PRIMUS Express. Comes in a net stuff sack. Dimensions: 1 l • 33.8 oz: Ø 125 x 150 mm • 4.9" x 5.9". Weight: 290 g • 10.2 oz.

**Part number: 734110**

### PRIMUS EtaPower™ Pot

La plus petite casserole de la série Eta est parfaite pour le randonneur solitaire qui se contente d'un récipient d'un litre. Le couvercle peut aussi être utilisé comme poêle à frire. Fabriquée en aluminium anodisé à chaud avec un revêtement intérieur de plusieurs couches de titane "non-adhésif". Peut contenir à la fois une cartouche de gaz de 230 grammes et par ex un réchaud PRIMUS Express. Livrée dans un filet. Dimensions: 1 l: Ø 125 x 150 mm. Poids: 290 g.

**N°réf. de l'article: 734110**



### PRIMUS EtaPower™ Pots

Primus EtaPower pots are made of hard anodized aluminum with a multi-layer titanium nonstick surface on the inside. The pots have lids and pot grippers and are equipped with a heat exchanger on the bottom, which makes your stove approx one third faster and more efficient. The pots are available in 1,2, 1,7, 2,1 and 2,9 l and can be used with most existing gas or multifuel burner on the market. Comes in a practical net stuff sack.

**Part number:**

**734630** Dimensions: 1,2 l • 40.5 oz: Ø 160 x 115 mm

• Ø 6.3" x 4.5". Weight: 260 g • 9.2 oz.

**733880** Dimensions: 1,7 l • 57.5 oz: Ø 170 x 90 mm • Ø 6.7" x 3.5". Weight: 347 g • 12.2 oz.

**733890** Dimensions: 2,1 l • 71 oz: Ø 180 x 110 mm • Ø 7.1" x 4.3". Weight: 412 g • 14.5 oz.

**734210** Dimensions: 2,9 l • 98 oz: Ø 190 x 120 mm • Ø 8" x 5.3". Weight: 446 g • 15.8 oz.

### PRIMUS EtaPower™ Pots

Les casseroles PRIMUS EtaPower™ sont fabriquées en aluminium anodisé brut avec un revêtement intérieur "non-adhésif" en titane multicouches. Les casseroles ont un couvercle et une poignée et sont également équipées d'un diffuseur de chaleur à la base, ce qui rend votre réchaud environ trois fois plus rapide et plus efficace. Les casseroles sont disponibles en 1,2 - 1,7 - 2,1 respectivement 2,9 l et peuvent être utilisées avec la plupart des gaz et combustibles multi-fuel existant sur le marché. Livrée dans un filet très pratique.

**N°réf. de l'article:**

**734630** Dimensions: 1,2 l: Ø 160 x 115 mm. Poids: 260 g.

**733880** Dimensions: 1,7 l: Ø 170 x 90 mm. Poids: 347 g.

**733890** Dimensions: 2,1 l: Ø 180 x 110 mm. Poids: 412 g.

**734210** Dimensions: 2,9 l: Ø 190 x 120 mm. Poids: 446 g.



• Titanium non-stick coating

### PRIMUS LiTech Super Set

Ultralight cooking set made of hard-anodized aluminium with a multilayer titanium non-stick surface on the inside. The set consists of two pots, a lid, a frying pan with handle and a separate pot gripper. Comes in a practical net stuff sack. Dimensions: 1.7 l • 57.5 oz: Ø 170 x 75 mm • 6.7" x 2.9". 2.1 l • 71 oz: Ø 180 x 95 mm • 7.1" x 3.7". Frying pan: Ø 165 (base) / 220 (top) x 50 mm • 6.5" (base) / 8.7" (top) x 2". Weight: 923 g • 32.5 oz.

**Part number: 733310**

### PRIMUS LiTech Super Set

Batterie de cuisine ultra-légère en aluminium traité par anodisation dure, dotée d'un revêtement en titane antiadhésif multicouches à l'intérieur. L'ensemble est constitué de deux casseroles d'un couvercle d'une poêle à frire avec poignée et d'une pince séparée. Livrée dans un filet très pratique. Dimensions: 1,7 l: Ø 170 x 75 mm. 2,1 l: Ø 180 x 95 mm. Poêle: Ø 165 (fond) / 220 (sommets) x 50 mm. Poids: 923 g.

**N°réf. de l'article: 733310**



• Titanium non-stick coating

### PRIMUS LiTech Cooking Set

Ultralight cooking set made of hard-anodized aluminium with a multilayer titanium non-stick surface on the inside. The set consists of two pots, a lid and a separate pot gripper. Comes in a practical net stuff sack. Dimensions: 1.7 l • 57.5 oz: Ø 170 x 75 mm • 6.7" x 2.9". 2.1 l • 71 oz: Ø 180 x 95 mm • 7.1" x 3.7". Weight: 664 g • 23.4 oz.

**Part number: 731691**

### PRIMUS LiTech Batterie de cuisine

Batterie de cuisine ultra-légère en aluminium traité par anodisation dure, dotée d'un revêtement en titane antiadhésif multicouches à l'intérieur. L'ensemble est constitué de deux casseroles, d'un couvercle et d'une pince séparée. Livrée dans un filet très pratique. Dimensions: 1,7 l: Ø 170 x 75 mm. 2,1 l: Ø 180 x 95 mm. Poids: 664 g.

**N°réf. de l'article: 731691**



• Titanium non-stick coating

### PRIMUS Eta CampLite Pot

The Eta CampLite Pot is an improved version of our award-winning EtaPower pots. The heat exchanger in the base of the saucepan increases the efficiency rate of your stove by approximately one third. That means significantly lower fuel use and reduced operating costs, making it an obvious choice for both the environment and your wallet. The Eta CampLite Pot also has sturdy handles and lid for easy handling.

**Part number:**

**734540** Dimensions: 1,7 l • 57.5 oz: Ø 170 x 90 mm • Ø 6.7" x 3.5". Weight: 347 g • 12.2 oz.

**734550** Dimensions: 2,1 l • 71 oz: Ø 180 x 110 mm • Ø 7.1" x 4.3". Weight: 412 g • 14.5 oz.

**734560** Dimensions: 2,9 l • 98 oz: Ø 190 x 120 mm • Ø 8" x 5.3". Weight: 446 g • 15.8 oz.

### PRIMUS Eta CampLite Pot

Eta CampLite Pot est le nouveau développement de notre casserole EtaPower bien connue dans le monde. Grâce au diffuseur de chaleur au fond de la casserole, le degré d'efficacité du réchaud augmente d'environ un tiers, ce qui conduit à une forte diminution de la consommation de combustible et des coûts de fonctionnement, le rendant ainsi le meilleur choix pour l'environnement et le porte-feuille. Eta CampLite Pot comporte en plus une vraie poignée et un couvercle pour une manipulation plus simple.

**N°réf. de l'article:**

**734540** Dimensions: 1,7 l: Ø 170 x 90 mm. Poids: 347 g.

**734550** Dimensions: 2,1 l: Ø 180 x 110 mm. Poids: 412 g.

**734560** Dimensions: 2,9 l: Ø 190 x 120 mm. Poids: 446 g.



### PRIMUS LiTech Trek Kettle

Ultra light saucepan and frying pan made of hard-anodized aluminium with a multilayer titanium non-stick surface on the inside. Folding handles and room for one 2207 gas cartridge. Comes in a practical net stuff sack. Volume 1 l • 33.8 oz. Dimensions: Ø 125 x 135 mm • 4.5" x 5". Weight: 267 g • 9.4 oz.

**Part number: 731722**

### PRIMUS LiTech Trek Kettle

Casserole ultra-légère et poêle en aluminium traité par anodisation dure. La poêle comporte un revêtement non-adhérent pratique. Poignée repliable, peut accueillir une bouteille de gaz 2207. Livrée dans un filet très pratique. Contient 1 l. Dimensions: Ø 125 x 135 mm. Poids: 267 g.

**N°réf. de l'article: 731722**



• Titanium non-stick coating



- Titanium non-stick coating

**PRIMUS LiTech Frying Pan**

Extremely lightweight frying pan made of hard-anodized aluminium with a multilayer titanium non-stick surface. Folding handle. Comes in a practical net stuff sack. Dimensions: Ø 165 (base) / 218 (top) x 50 mm • 6.5" (base) / 8.6" (top) x 2". Weight: 250 g • 8.8 oz.

**Part number: 731711**

**PRIMUS LiTech Poêle à frire**

Poêle à frire extrêmement légère en aluminium traité par anodisation dure, dotée d'un revêtement en titane anti-adhésif multicouches à l'intérieur. Poignée repliable. Livrée dans un filet très pratique. Dimensions: Ø 165 (fond) / 218 (sommets) x 50 mm. Poids: 250 g.

**N°réf. de l'article: 731711**



**PRIMUS LiTech Coffee/Tea Kettles**

Extremely lightweight coffee/tea kettles made of hard-anodized aluminium. Folding handle. Comes in a practical net stuff sack.

**Part number:**

**731701:** Volume 0.9 l • 30.4 oz. Dimensions: Ø 153 x 55 mm • 6" x 2.2". Weight: 190 g • 6.7 oz.

**733810:** Volume 1.5 l • 50.7 oz. Dimensions: Ø 153 x 110 mm • 6" x 4.3". Weight: 205 g • 7.2 oz.

**PRIMUS LiTech Cafetière/Théière**

Cafetière/théière extrêmement légères en aluminium traité par anodisation dure. Poignée repliable. Livrées dans un filet très pratique.

**N°réf. de l'article:**

**731701:** Contient 0,9 L. Dimensions: Ø 153 x 55 mm. Poids: 190 g.

**733810:** Contient 1,5 L. Dimensions: Ø 153 x 110 mm. Poids: 205 g.



**PRIMUS LiTech Coffee/Tea Press Kit**

With the Primus Coffee/Tea Press Kit, chilly hikers, fishermen, hunters and other outdoor folk can enjoy a nice, warm cup of fresh coffee or loose leaf tea outdoors. The pot can also be used on its own to cook food. Dimensions: Ø 130 x 127 mm • 5.1" x 5". Weight: 320 g • 11.3 oz.

**Part number: 734650**

**PRIMUS LiTech Coffee/Tea Press Kit**

Avec le Kit Presse à Café/Thé Primus, les randonneurs, pêcheurs, chasseurs et autres amateurs de plein air peuvent se délecter d'un café fraîchement moulu ou d'un thé en vrac en pleine nature. La casserole peut aussi être utilisée séparément pour la préparation des repas. Dimensions: Ø 130 x 127 mm. Poids: 320 g.

**N°réf. de l'article: 734650**



**PRIMUS Coffee/Tea press**

Fits EtaExpress, EtaPower Pot (1 litre size) and LiTech Trek Kettle (1 litre size) (731722) Dimensions: Ø 130 x 120 mm • Ø 5.1" x 4.7". Weight: 65 g • 2.4 oz.

**Part number: 734520**

**PRIMUS Coffee/Tea press**

Convient aux EtaExpress, EtaPower Pot 1 l et LiTech Trek Kettle 1 l (731722). Dimensions: Ø 130 x 120 mm Poids: 65 g.

**N°réf. de l'article: 734520**



- Titanium non-stick coating
- Hard-anodized aluminium

**PRIMUS Lid/Frying pan**

Fits all Primus 2.1-liter cooking pots as a lid. Dimensions: Ø 200 x 35 mm • Ø 7.9" x 1.4". Weight: 150 g • 5.3 oz.

**Part number: 734590**

**PRIMUS Couvercle/poêle**

Convient comme couvercle à tous les ustensiles de cuisson Primus 2,1 l. Dimensions: Ø 200 x 35 mm. Poids: 150 g.

**N° réf. de l'article: 734590**

**PRIMUS Lid**

**Part number:**

**734600** Fits all Primus 1.7 l pots. Dimensions: Ø 180 x 15 mm • Ø 7.1" x 0.6". Weight: 90 g • 3.2 oz.

**734610** Fits all Primus 2.1 & 2.9 l pots. Dimensions: Ø 195 x 15 mm • Ø 7.7" x 0.6". Weight: 97 g • 3.4 oz

**PRIMUS Couvercle**

**N° réf. de l'article:**

**734600** Convient à toutes les casseroles Primus 1,7 l. Dimensions: Ø 180 x 15 mm. Poids: 90 g.

**734610** Convient à toutes les casseroles Primus 2,1 l & 2,9 l. Ø 195 x 15 mm. Poids: 97 g.



- Hard-anodized aluminium

**PRIMUS Pot Gripper**

Aluminium pot gripper for Primus pans. With protection to avoid damaging the "non-stick" surface of the pots. Dimensions: 130 x 39 x 42 mm • 5.1" x 1.5" x 1.6". Weight: 45 g • 1.6 oz.

**Part number: 731760**

**PRIMUS Pince**

Pince en aluminium pour casseroles Primus. Avec protection pour éviter d'endommager le revêtement non-adhérent de la paroi des casseroles. Dimensions: 130 x 39 x 42 mm. Poids: 45 g.

**N° réf. de l'article: 731760**



**PRIMUS EtaPower™ Insulation Bag**

A perfect accessory for cooking to keep the pasta warm while you fry the rest of your food. The pot should be allowed to cool for approximately 30 seconds before it is placed in the insulation bag. Dimensions: 220 x 120 mm • 8.6" x 4.7". Weight: 290 g • 10.2 oz.

**Part number: 734200**

**PRIMUS EtaPower™ Insulation Bag (Sac isolant)**

Un accessoire parfait lors de la préparation des repas qui maintient au chaud les pâtes alors que vous cuisez autre chose. Laisser refroidir la casserole environ 30 secondes avant de l'introduire dans le sac isolant. Dimensions: 220 x 120 mm. Poids: 290 g.

**N°réf. de l'article: 734200**



**PRIMUS Super Pouch**

A really durable storage bag for stoves and pots. Made out of heavy-duty Rip-Stop nylon with a pocket for spare parts and cutlery. Dimensions: 265 x 285 mm • 10.4" x 11.2", Weight: 135 g • 4.7 oz.

**Part number: 733910**

**PRIMUS Super Pouch**

Un véritable sac d'emballage résistant pour réchaud et casseroles. Fabriqué en nylon épais Rip-Stop avec pochette pour accessoires et couverts. Dimensions: 265 x 285 mm, Poids: 135 g.

**N°réf. de l'article: 733910**



**PRIMUS Cutlery Kit – Titanium**

With the addition of a knife, our popular, ultralight titanium cutlery kit is complete. It now includes a fork, knife, and spoon held together by a cord and stopper. Dimensions: 175 x 35 mm • 6.8" x 1.4". Weight: 44 g • 1.5 oz.

**Part number: 730841**

**PRIMUS Service de couverts – Titane**

Notre service de couverts populaire et ultra-léger en titane est maintenant complet grâce à l'ajout d'un couteau à celui-ci. Il est maintenant constitué d'une fourchette, d'un couteau et d'une cuillère tenus ensemble par un cordon avec stoppeur. Dimensions: 175 x 35 mm. Poids: 44 g.

**N°réf. de l'article: 730841**



**PRIMUS Field Cutlery Kit**

Spoon, knife and fork made of high-quality 18/8 stainless steel. The cutlery is held together by a cord and stopper. Dimensions: 175 x 40 mm • 6.8" x 1.6". Weight: 91 g • 3.2 oz.

**Part number: 730830**

**PRIMUS Kit couverts**

Cuillère, couteau et fourchette en acier inoxydable 18/8 de qualité supérieure. Les articles de ce kit sont réunis par un cordon avec stoppeur. Dimensions: 175 x 40 mm. Poids: 91 g.

**N° réf. de l'article: 730830**





**PRIMUS Lightweight Cutlery Kit**

Fork, knife, and spoon made of durable PC-plastic. Light and easy to wash. Dimensions: 175 x 45 mm • 6.8" x 1.7". Weight: 26 g • 0.9 oz.

**Part number: 732771**

**PRIMUS Kit couverts légers**

Fourchette, couteau, et cuillère en plastique PC résistant. Léger et facile à laver. Dimensions: 175 x 45 mm. Poids: 26 g.

**N° réf. de l'article: 732771**



**PRIMUS Folding Spork**

Lightweight spork made of PC-plastic in folding design. An all-around eating utensil that is compact, ultralight, and easy to carry anywhere. Perfect for backpackers, adventurers, and anyone who needs lightweight utensils. Comes in four colors. Dimensions: 105 x 40 x 23 mm • 4.1" x 1.6" x 0.9". Weight: 10.5 g • 0.35 oz.

**Part number:**

- 734010** - Red (pin-pack, 1 pc)
- 734011** - Black (pin-pack, 1 pc)
- 734012** - Green (pin-pack, 1 pc)
- 734013** - White (pin-pack, 1 pc)
- 734014** - Red (pack of 48 pcs)
- 734015** - Black (pack of 48 pcs)
- 734016** - Green (pack of 48 pcs)
- 734017** - White (pack of 48 pcs)
- 734018** - Mixed standard colours (display tube, pack of 200 pcs)
- 734019** - Mixed standard colours (display box, pack of 48 pcs)
- 734020** - Mixed fashion colours (display tube, pack of 200 pcs)

**PRIMUS Spork pliable**

Spork (cuillère + fourchette) pliable en polycarbonate ultra léger. Un couvert multifonction qui est à la fois compact, ultra léger et facile à emporter partout avec soi. Parfait pour les randonneurs, les aventuriers et tous ceux qui ont besoin de couverts légers. Existe en quatre couleurs différentes. Dimensions: 105 x 40 x 23 mm. Poids: 10,5 g.

**N° réf. de l'article:**

- 734010** - Rouge (petit paquet 1 pc)
- 734011** - Noir (petit paquet 1 pc)
- 734012** - Vert (petit paquet 1 pc)
- 734013** - Blanc (petit paquet 1 pc)
- 734014** - Rouge (par 48)
- 734015** - Noir (par 48)
- 734016** - Vert (par 48)
- 734017** - Blanc (par 48)
- 734018** - Couleurs standard mélangées (Tube de présentation, par 200)
- 734019** - Couleurs standard mélangées (boite de présentation, par 48)
- 734020** - Couleurs mode mélangées (tube de présentation, par 200)

- Dishwasher safe
- Extremely durable
- Weighs only 10.5 g / 0.35 oz

**SPORK UP YOUR LIFE!**



734010



734019



734018



734020

**PRIMUS Meal Set**

A complete eight-piece set that includes everything you need to eat out in the great outdoors. Two deep plates, a spice jar with three compartments, a small container that can be used for oil or washing-up liquid, storage container with tight-fitting lid, an outdoor cup, folding spork and an all-in-one cutting board, colander, grater and knife. Dimensions: 230 x 145 x 60 mm • 9" x 5.7" x 2.4". Weight: 360 g • 12.7 oz.

**Part number:**

- 734000** - Red
- 734001** - Black
- 734002** - Green

**PRIMUS Meal Set**

Un kit complet de huit pièces qui comprend tout le nécessaire à un repas en plein air. Deux assiettes creuses, une boîte à épices à trois compartiments, un petit récipient pour par ex le liquide vaisselle ou l'huile, une boîte de rangement à fermeture étanche, une tasse, un spork pliable ainsi qu'une planche à découper combinant passoire, râpe et couteau. Dimensions: 230 x 145 x 60 mm. Poids: 360 g.

**N° réf. de l'article:**

- 734000** - Rouge
- 734001** - Noir
- 734002** - Vert



- Dishwasher-safe
- Microwave-safe

**PRIMUS Field Cup Set**

A compact set designed by the Scandinavian designer Nicolai Wiig Hansen. The set contains a food cup with lid (400 ml • 13.53 oz), drinking cup (200 ml • 6.76 oz), spoon, fork and knife. Dimensions: 170 x 100 x 73 mm • 6.7" x 3.9" x 2.9". Weight: 156 g • 5.5 oz.

**Part number:**

- 734700** - Red
- 734701** - Black
- 734702** - Green
- 734703** - Mixed fashion colours (pack of 6 pcs)
- 734704** - Mixed fashion colours (display, pack of 24 pcs)

**PRIMUS Field Cup Set**

Un kit compact conçu par le designer scandinave Nicolai Wiig Hansen. Le kit contient une tasse alimentaire avec couvercle (400ml), une tasse pour boisson (200 ml), une cuillère, une fourchette et un couteau. Dimensions: 170 x 100 x 73 mm. Poids: 156 g.

**N° réf. de l'article:**

- 734700** - Rouge
- 734701** - Noir
- 734702** - Vert
- 734703** - Couleurs standard mélangées (par 6)
- 734704** - Couleurs standard mélangées (présentoir, par 24)



734701



734702



734703



734704

**PRIMUS Spice Jar**

A convenient way to take your favourite seasonings along. Three compartments in the same container hold spices to pep up any tasteless outdoor food! Made from durable, hygienic polypropylene plastic. Dimensions: 47 x 44 x 28 mm • 1.9" x 1.7" x 1.1". Weight: 15 g • 0.5 oz.

**Part number:**

- 734450** - Red
- 734451** - Black
- 734452** - Green
- 734458** - Multi colours (display tube, pack of 102 pcs)

**PRIMUS Boîte à épices**

Une solution astucieuse pour emporter vos épices préférées. Trois compartiments dans le même récipient contiennent les épices qui relèvent tous les plats de plein air trop fades. Fabriquée en plastique PP résistant et hygiénique. Dimensions: 47 x 44 x 28 mm. Poids: 15 g.

**N° réf. de l'article:**

- 734450** - Rouge
- 734451** - Noir
- 734452** - Vert
- 734458** - Couleurs Mélangées (tube de présentation, par 102)



734450

734458

- Dishwasher-safe



- Dishwasher-safe
- Microwave-safe

**PRIMUS Outdoor Cup**

A modern version of the classic outdoor cup, made of durable, hygienic polypropylene plastic. Holds 0.25 liter • 8.5 oz. Dimensions: 115 x 105 x 45 mm • 4.5" x 4.1" x 1.8" Weight: 33 g • 1.2 oz.

**Part number:**  
**734460** - Red  
**734461** - Black  
**734462** - Green

**PRIMUS Tasse de camping**

Une tasse classique en finition moderne, fabriquée en plastique PP résistant et hygiénique. La tasse contient 0,25 l. Dimensions: 115 x 105 x 45 mm. Poids: 33 g

**N° réf. de l'article:**  
**734460** - Rouge  
**734461** - Noir  
**734462** - Vert

**PRIMUS Windscreen**

This windscreen fits Primus ExpressStove, MicronStove Ti, TiLite, ClassicTrail and most other cartridge-mounted gas stoves. The Primus windscreen significantly increases the efficiency of your stove. Increased efficiency means faster boiling time and less fuel consumption – thereby making your stove more environmentally friendly. It's easy to take along with you, as it packs conveniently around the gas cartridge. Dimensions: Ø 100 x 76 mm • Ø 3.9" x 3.0". Weight: 60 g • 2.1 oz.

**Part number: 734670**

**PRIMUS Pare-vent**

Ce pare-vent s'adapte aux réchauds Primus ExpressStove, MicronStove Ti, TiLite, ClassicTrail et à la plupart des réchauds à gaz montés directement sur la cartouche. Le pare-vent Primus augmente nettement l'efficacité du réchaud. Une efficacité plus importante implique un temps d'ébullition réduit, une réduction de consommation de combustible et rend donc votre réchaud plus respectueux de l'environnement. Il est facile à emporter car il se range facilement autour de votre cartouche de gaz. Dimensions: Ø 100 x 76 mm. Poids: 60 g

**N° réf. de l'article: 734670**



**PRIMUS Toaster**

Collapsible toaster in stainless steel. The mesh net distributes the heat over the bread slices. Should only be used with a gas stove. Dimensions: 140 x 167 x 15 mm • 5.5" x 6.6" x 0.6" (collapsed). Weight: 186 g • 6.6 oz.

**Part number: 720661**

**PRIMUS Grille-pain**

Grille-pain dépliant en acier inoxydable. La grille répartit la chaleur sur les tranches de pain. A n'utiliser qu'avec des réchauds au GPL. Dimensions: 140 x 167 x 15 mm (déplié). Poids: 186 g.

**N° réf. de l'article: 720661**



**PRIMUS Foot Rest**

Recommended to increase stability for stoves that screw directly onto the gas cartridge, especially when using large pots or cooking on uneven surfaces. The footrest attaches to the base of the cartridge. Also fits other brand cartridges. Dimensions: 27 x 140 x 37 mm • 1.1" x 5.5" x 1.5". Weight: 22 g • 0.8 oz.

**Part number: 721171**

**PRIMUS Trépied**

Recommandé pour augmenter la stabilité des réchauds qui se vissent directement sous la bouteille de gaz, surtout lors de l'utilisation de grandes marmites ou sur des surfaces accidentées. Ce trépied se fixe au fond de la bouteille de gaz et s'adapte également aux bouteilles d'autres marques. Dimensions: 27 x 140 x 37 mm. Poids: 22 g.

**N° réf. de l'article: 721171**



- Also fits 2206 & Cassette Gas

**PRIMUS Ignition Steel**

The optimal way of starting a fire or lighting your stove in all weather conditions. Water resistant – works in rain and snow. Durable – can be used thousands of times. Effective – the sparks are about 3000°C.

**Part number:**  
**733331** - Small. Dimensions: Ø 22 x 67 mm • 0.9" x 2.6". Weight: 22 g • 0.8 oz.  
**732391** - Medium. Dimensions: Ø 24 x 78 mm • 0.9" x 3.1". Weight: 26 g • 0.9 oz.  
**732401** - Large. Dimensions: Ø 24 x 100 mm • 0.9" x 3.9". Weight: 50 g • 1.8 oz.

**PRIMUS Pierre à feu**

Le moyen le plus efficace pour allumer un feu ou votre réchaud, dans toutes les conditions climatiques. Résiste à l'eau fonctionne sous la pluie et la neige. Durable – peut être utilisé des milliers de fois. Efficace – la température approximative des étincelles est de 3000°C.

**N° réf. de l'article:**  
**733331** - Petite Dimensions: Ø 22 x 67 mm. Poids: 22 g.  
**732391** - Moyenne. Dimensions: Ø 24 x 78 mm. Poids: 26 g.  
**732401** - Grande. Dimensions: Ø 24 x 100 mm. Poids: 50 g.



**PRIMUS PowerLighter**

Primus new PowerLighter with a narrow flame makes it simple to light your stove or camp fire. A temperature of 1300°C facilitates lighting liquid fuels in bad weather. Dimensions: 80 x 50 x 20 mm • 3.15" x 2.0" x 0.8". Weight: 67 g • 2.4 oz.

**Part number:**  
**733307** - Black  
**733308** - Red

**PRIMUS PowerLighter**

Le nouveau PowerLighter Primus à flamme extrêmement étroite simplifie l'allumage de votre réchaud ou de votre feu de bois. La température de la flamme est de 1300°C, ce qui facilite l'allumage des carburants volatiles dans des mauvaises conditions climatiques. Dimensions: 80 x 50 x 20 mm. Poids: 67 g.

**N° réf. de l'article:**  
**733307** - Noire  
**733308** - Rouge



**PRIMUS Filling Adapter**

This product can easily be connected to the Primus PowerGas single use gas cartridges. The filling adapter can be used to fill Primus PowerLighter and other refillable lighters. Dimensions: Ø 15 x 40 mm • Ø 0.6" x 1.6". Weight: 19 g • 0.7 oz.

**Part number: 733870**

**PRIMUS Adaptateur de remplissage**

Ce produit peut être facilement raccordé à la cartouche jetable Primus PowerGas. L'adaptateur de remplissage peut également être utilisé pour remplir le briquet Primus PowerLighter et autres briquets rechargeables. Dimensions: Ø 15 x 40 mm. Poids: 19 g.

**N° réf. de l'article: 733870**



- The classic!

**PRIMUS 4 Season Mug**

A durable, double-walled mug in polished high-quality 18/8 stainless steel.

**Part number:**  
**732250** Volume: 0.2 l • 8 oz. Dimensions: Ø 71 x 77 mm • 2.8" x 3". Weight: 111 g • 3.9 oz.  
**732260** Volume: 0.3 l • 10 oz. Dimensions: Ø 75 x 90 mm • 2.9" x 3.5". Weight: 141 g • 5 oz.

**PRIMUS 4 Season Mug**

Un mug durable et résistant, à double paroi isolante en acier inoxydable poli 18/8 de qualité supérieure.

**N° réf. de l'article:**  
**732250** Contient 0,2 L. Dimensions: Ø 71 x 77 mm. Poids: 111 g.  
**732260** Contient 0,3 L. Dimensions: Ø 75 x 90 mm. Poids: 141 g.



**PRIMUS Suspension Kit**

For those who want to take a break on the mountainside or cook on board a boat. The wires hold the stove and gas cartridge or fuel bottle together, but are separated at the top for easier access to pots and pans. Available in two versions for stoves with three or four legs.

**Part number:**  
**721220** For a stove with three legs. Dimensions: 170 x 170 mm • 6.7" x 6.7". Weight: 50 g • 1.8 oz.  
**733320** For a stove with four legs. Dimensions: 140 x 140 mm • 5.5" x 5.5". Weight: 65 g • 2.2 oz.

**PRIMUS Kit de suspension**

Pour ceux et celles qui souhaitent souffler un instant à la montagne ou cuisiner sur un bateau. Les fils métalliques maintiennent la cohésion de l'ensemble réchaud/bouteille de gaz ou de combustible, mais ils peuvent être séparés en leur sommet pour vous permettre d'accéder plus facilement à vos casseroles. Existents en deux versions un pour réchauds à trois pieds, un pour réchauds à quatre pieds.

**N° réf. de l'article:**  
**721220** Pour réchaud à trois pieds. Dimensions: 170 x 170 mm. Poids: 50 g.  
**733320** Pour réchaud à quatre pieds. Dimensions: 140 x 140 mm. Poids: 65 g.

**PRIMUS Windscreen and Heat Reflector Set**

For OmniFuel, MultiFuel, Gravity, VariFuel and EasyFuel stoves. Increases heat output and shortens cooking time. The aluminium heat reflector focuses heat on the pot and preheating coil. Dimensions: windscreen 750 x 150 mm • 29.5" x 5.9", heat reflector Ø 250 mm. Weight: 87 g • 3.1 oz

**Part number: 721720**

**PRIMUS Ensemble pare-vent et réflecteur de chaleur**

Pour réchauds OmniFuel, MultiFuel, Gravity, VariFuel et EasyFuel. Accroît la puissance de chauffe et réduit le temps de cuisson nécessaire. Le réflecteur de chaleur en aluminium concentre la chaleur sur la marmite et le serpentin de préchauffage. Dimensions: Pare-vent 750 x 150 mm, Réflecteur de chaleur Ø 250 mm. Poids: 87 g.

**N° réf. de l'article: 721720**



# PRIMUS Vacuum Bottles

- Double silicone seals
- Doubles joints d'étanchéité en silicone
- Quick-Stop
- Système de fermeture Quick-Stop
- Easy to dismantle and clean
- Facile à démonter et à laver
- Vacuum insulation
- Isolation sous vide
- Stainless steel inside & outside
- Intérieur et extérieur en acier inoxydable
- Powder-coated exterior
- Extérieur laqué poudre
- Silver plating for ultimate insulation
- Plaquée argent pour garantir une isolation exceptionnelle



## PRIMUS C&H Vacuum Bottle

Double-walled vacuum bottle in powder coated stainless steel with "Quick-Stop" seal and combined lid and mug. Offers excellent insulation and low weight without sacrificing durability. Delivered with an extra stopper.

### Part number:

- 734492** Dimensions: Ø 68 x 175 mm • 2.7" x 6.9". Volume: 0.25 l • 8.4 oz. Weight: 263 g • 9.3 oz.
- 732352** Dimensions: Ø 68 x 210 mm • 2.7" x 8.3". Volume: 0.35 l • 11.8 oz. Weight: 286 g • 10.1 oz.
- 732362** Dimensions: Ø 68 x 245 mm • 2.7" x 9.7". Volume: 0.50 l • 16.9 oz. Weight: 338 g • 11.9 oz.
- 732372** Dimensions: Ø 86 x 260 mm • 3.4" x 10.2". Volume: 0.75 l • 25.4 oz. Weight: 506 g • 17.8 oz.
- 732382** Dimensions: Ø 86 x 297 mm • 3.4" x 11.7". Volume: 1.0 l • 33.8 oz. Weight: 563 g • 19.9 oz.

## PRIMUS C&H Bouteille isotherme

Bouteille isotherme sous vide à double paroi isolante en acier laqué poudre inoxydable, munie d'une fermeture « QuickStop » et d'un couvercle servant de gobelet. Offre une isolation excellente et une ultra-légereté sans pour autant compromettre sa longévité. Livrée avec un bouchon de rechange.

### N° réf. de l'article:

- 734492** Dimensions: Ø 68 x 175 mm. Volume: 0,25 l. Weight: 240 g
- 732352** Dimensions: Ø 68 x 210 mm. Contient: 0,35 l. Poids: 286 g.
- 732362** Dimensions: Ø 68 x 245 mm. Contient: 0,50 l. Poids: 338 g.
- 732372** Dimensions: Ø 86 x 260 mm. Contient: 0,75 l. Poids: 506 g.
- 732382** Dimensions: Ø 86 x 297 mm. Contient: 1,0 l. Poids: 563 g.

- Approximate values, measured with a standard stopper and ambient temperature of 20°C (68°F). The vacuum bottle is pre-heated for 5 min with hot water at 95°C.
- Valeur approximative mesurée avec un couvercle normal et à une température ambiante de 20°C. La bouteille isotherme est pré-chauffée pendant 5 minutes remplie d'eau chaude à 95°C.

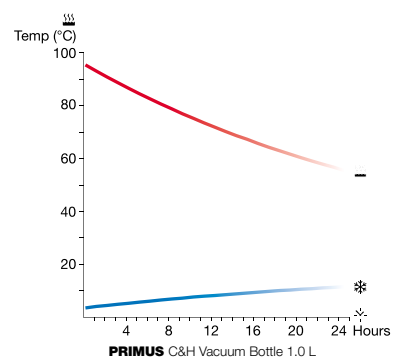
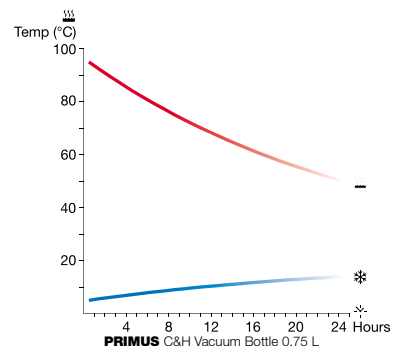
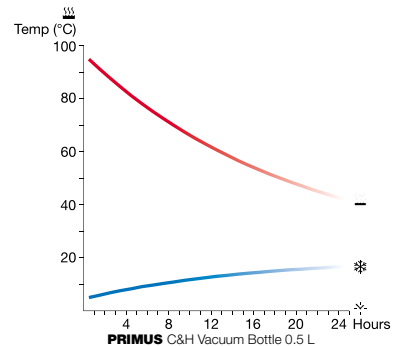
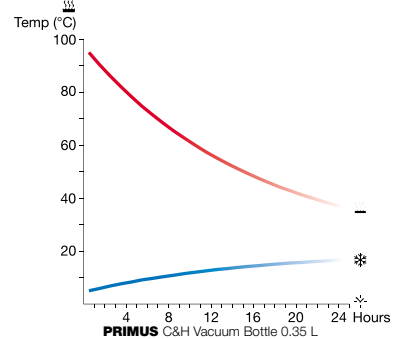
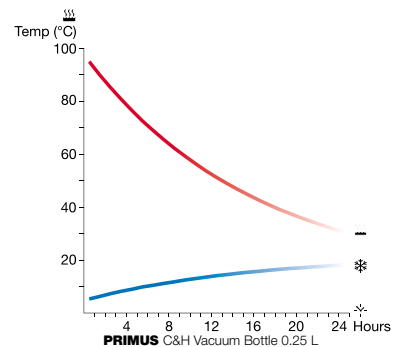

## PRIMUS C&H Food Vacuum Bottle

Double walled vacuum bottle in powder coated stainless steel with "Quick Stop" closure and large opening to easily access bottle contents. The cover doubles as a mug. Two sizes, 1.2 and 1.5 l. Good insulating qualities and low weight without sacrificing durability.

### Part number:

- 732782** Dimensions: Ø 110 x 260 mm • 4.3" x 10.2". Volume: 1.2 l • 41 oz. Weight: 835 g • 29.4 oz.
- 732792** Dimensions: Ø 110 x 288 mm • 4.3" x 11.3". Volume: 1.5 l • 53 oz. Weight: 885 g • 31.2 oz.

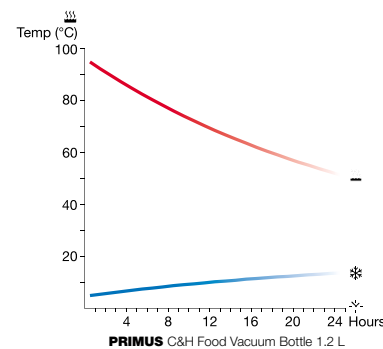

## PRIMUS C&H Bouteille isotherme

Bouteille isotherme en acier inoxydable laqué poudre à double paroi avec fermeture "Quick Stop" et un goulot large pour accès facile au contenu. Le couvercle sert également de gobelet. Deux formats, 1,2 et 1,5 l. Bonne isolation et poids réduit sans perte de robustesse.

### N° réf. de l'article:

- 732782** Dimensions: Ø 110 x 260 mm. Contient: 1,2 l. Poids: 835 g.
- 732792** Dimensions: Ø 110 x 288 mm. Contient: 1,5 l. Poids: 885 g.



## PRIMUS C&H Lunch Jug

Light, compact and portable double-walled vacuum jug in powder coated stainless steel with a leak-proof lid. Wide mouth which makes it easy to fill, serve from and clean. The excellent insulation makes it perfect for your food, drink or soup.

### Part number:

- 733772** Dimensions Ø 85 mm x 130 mm • 3.3" x 5.1" Volume 0.35 l • 12 oz. Weight 265 g • 9.3 oz.
- 733782** Dimensions Ø 85 mm x 175 mm • 3.3" x 6.9" Volume 0.5 l • 17 oz. Weight 314 g • 11 oz.

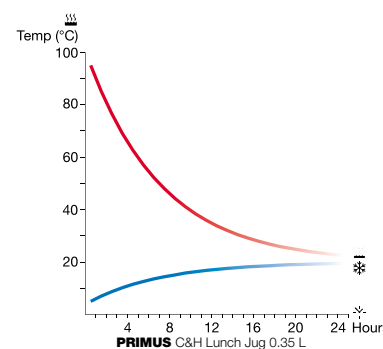

## PRIMUS C&H Bouteille isotherme déjeuner

Récipient double paroi avec vide d'air, léger, compact et portatif en acier inoxydable laqué poudre avec un couvercle anti-fuite. Une large ouverture facilite le remplissage et le nettoyage et permet de manger directement à partir du récipient. Sa bonne capacité d'isolation le rend parfait pour votre nourriture, vos boissons ou soupes.

### N° réf. de l'article:

- 733772** Dimensions: Ø 85 mm x 130 mm. Volume: 0,35 l. Poids: 265 g.
- 733782** Dimensions: Ø 85 mm x 175 mm. Volume: 0,5 l. Poids: 314 g.

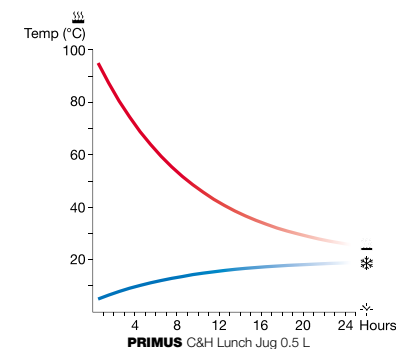

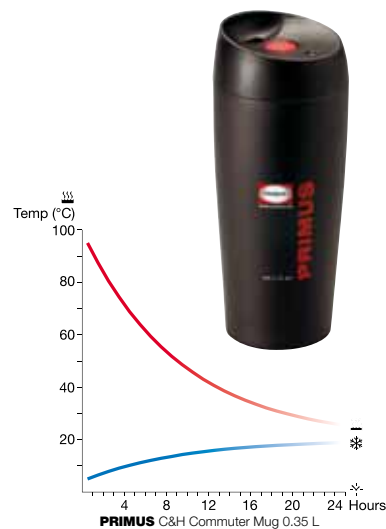

**PRIMUS C&H Commuter Mug 0.4 L (14 oz)**

Powder coated stainless steel vacuum insulated mug that holds 0.4 l (14 oz) of your favorite beverage. The mug will keep your beverage cold or hot when you are on the go. Silicone seals insure no spills. Just click to open and click to seal with one simple button. Accommodates a wide variety of car cup holders. Dimensions: Ø 81 x 197 • 3.2" x 7.8" mm. Volume: 0.4 l • 14 oz. Weight: 350 g • 12.3 oz.

**Part number: 733832**



**PRIMUS C&H Tasse de voyage 0.4 L**

Tasse isolante en acier laqué poudre inoxydable à double paroi qui contient 0.4 l de votre boisson préférée. La tasse conserve votre boisson froide ou chaude pendant vos voyages. Des joints en silicone empêchent les débordements. Cliquer simplement sur le bouton pour ouvrir et cliquer de nouveau pour refermer. S'adapte à une large gamme de porte-gobelet de voiture. Contient: 0,4 l. Dimensions: Ø 81 x 197 mm. Poids: 350 g.

**N° réf. de l'article: 733832**



**PRIMUS Commuter Mug 0.4 L (14 oz)**

PC-plastic double-walled mug that holds 0.4 l (14 oz) of your favorite beverage. Silicone seals insure no spills. Just click to open and seal it with one simple button. Accommodates a wide variety of car cup holders. Dimensions: Ø 81 x 197 mm. Volume: 0.4 l • 14 oz. Weight: 280 g • 9.9 oz.

**Part number:**

**733842** - Red  
**733849** - Mixed fashion colours

**PRIMUS Tasse Commuter 0.4 L**

Tasse isolante en plastique PC à double paroi qui contient 0.4 l de votre boisson préférée. Des joints en silicone empêchent les débordements. Cliquer simplement sur le bouton pour ouvrir et cliquer de nouveau pour refermer. S'adapte à une large gamme de porte-gobelet de voiture. Dimensions: Ø 81 x 197 mm. Contient: 0,4 l. Poids: 280 g.

**N° réf. de l'article:**

**733842** - Rouge  
**733849** - Couleurs mode mélangées



**PRIMUS Oval Drinking Bottle**

Oval water bottle in powder-coated aluminium. To not affect taste the bottle is internally surface-treated according to food standards. Volume: 0,4 l • 13.5 oz. Dimensions: 95 x 50 x 160 mm • 3.7" x 2.0" x 6.3". Weight: 107 g • 3.8 oz.

**Part number: 734502**

**PRIMUS. Gourde Ovale**

Gourde ovale en aluminium laqué poudré. Les surfaces internes sont traitées et conformes aux normes applicables dans le domaine alimentaire pour ne pas affecter le goût de vos boissons. Volume: 0,4 l. Dimensions: 95 x 50 x 160 mm. Poids: 107 g.

**N° réf. de l'article: 734502**

**PRIMUS Drinking Bottle - Aluminium**

Traditional drinking bottle in powder coated aluminium. To not affect taste the bottle is internally surface-treated according to food standards. The bottle comes with a sport cork. An extra cork with a carabiner is included for the outdoor enthusiast.

**Part number:**

**732202** Dimensions: Ø 72 x 210 mm • 2.8" x 8.3". Volume: 0.6 l • 20.3 oz. Weight: 142 g • 5 oz.  
**732212** Dimensions: Ø 80 x 265 mm • 3.1" x 10.4". Volume: 1.0 l • 33.8 oz. Weight: 175 g • 6.2 oz.

**PRIMUS Gourde - Aluminium**

Gourde traditionnelle en aluminium laqué poudre. Les surfaces internes sont traitées et conformes aux normes applicables dans le domaine alimentaire pour ne pas affecter le goût de vos boissons. La gourde est équipée d'un bouchon d'ouverture et de fermeture de type sportif. Livré avec un bouchon-vis supplémentaire à mousqueton pour les mordus du plein air.

**N° réf. de l'article:**

**732202** Dimensions: Ø 72 x 210 mm. Contient: 0,6 l. Poids: 142 g.  
**732212** Dimensions: Ø 80 x 265 mm. Contient: 1,0 l. Poids: 175 g.



• Powder coated aluminium

**PRIMUS Drinking Bottle - Stainless steel**

Traditional drinking bottle in powder coated stainless steel. The bottle comes with a sport cork. An extra cork with a carabiner is included for the outdoor enthusiast.

**Part number:**

**732203** Dimensions: Ø 72 x 210 mm • 2.8" x 8.3". Volume: 0.6 l • 20.3 oz. Weight: 160 g • 5.6 oz.  
**732213** Dimensions: Ø 80 x 265 mm • 3.1" x 10.4". Volume: 1.0 l • 33.8 oz. Weight: 205 g • 7.2 oz.

**PRIMUS Gourde - Acier inoxydable**

Gourde traditionnelle en acier inoxydable laqué poudre. La gourde est équipée d'un bouchon d'ouverture et de fermeture de type sportif. Livré avec un bouchon-vis supplémentaire à mousqueton pour les mordus du plein air.

**N° réf. de l'article:**

**732203** Dimensions: Ø 72 x 210 mm. Contient: 0,6 l. Poids: 160 g.  
**732213** Dimensions: Ø 80 x 265 mm. Contient: 1,0 l. Poids: 205 g.



• Powder coated stainless steel

**PRIMUS Outdoor Bottle - Stainless steel**

Primus outdoor bottle made in single-walled stainless steel. The bottle is lightweight, and has a wide mouth which makes it both simple to clean and fill. Stainless steel is durable and does not emit toxins which many traditional PC bottles do. The powder coated exterior surface also makes it scratch-proof.

**Part number:**

**732801** Dimensions: Ø 78 x 190 mm • 3.1" x 7.5". Volume: 0.6 l • 20.3 oz. Weight: 175 g • 6.2 oz.  
**732811** Dimensions: Ø 90 x 230 mm • 3.5" x 9.1". Volume: 1.0 l • 33.8 oz. Weight: 220 g • 7.8 oz.

**PRIMUS Bouteille de plein air - Acier inoxydable**

Bouteille de plein air Primus en acier inoxydable à simple paroi. La bouteille est légère et a un goulot large qui la rend facile à remplir et à nettoyer. L'acier inoxydable est robuste et n'émet pas de toxines comme la plupart des bouteilles en PC. La surface extérieure poudrée la rend aussi résistante aux rayures.

**N° réf. de l'article:**

**732801** Dimensions: Ø 78 x 190 mm. Contient: 0,6 l. Poids: 175 g.  
**732811** Dimensions: Ø 90 x 230 mm. Contient: 1,0 l. Poids: 220 g.



• Powder coated stainless steel

# PRIMUS Spare Parts



**PRIMUS ErgoPump™**

Fuel pump 732231 for OmniFuel, MultiFuel, EtaPower MF and Gravity MF. 732240 for VariFuel and Gravity VF.

**Part number:**

**732231** Dimensions: 66 x 41 x 179 mm • 2.6" x 1.6" x 7". Weight: 102 g • 3.6 oz.

**732240** Dimensions: 61 x 41 x 179 mm • 2.4" x 1.6" x 7". Weight: 105 g • 3.7 oz.

**PRIMUS ErgoPump™**

Pompe à combustible 732231 pour réchauds OmniFuel, MultiFuel, EtaPower MF et Gravity MF. 732240 pour VariFuel et Gravity VF.

**N° réf. de l'article:**

**732231** Dimensions: 66 x 41 x 179 mm. Poids: 102 g.

**732240** Dimensions: 61 x 41 x 179 mm. Poids: 105 g.



**Service Kit**

For MultiFuel and VariFuel. Weight: 55 g • 1.9 oz.

**Part number: 721290**

**Jeu de pièces de rechange**

Disponible pour les réchauds MultiFuel et VariFuel. Poids: 55 g

**N° réf. de l'article: 721290**



**Multi Tool**

For OmniFuel, MultiFuel and VariFuel. With jet cleaner. Dimensions: 80 x 17 x 15 mm • 3.1" x 0.7" x 0.6". Weight: 42 g • 1.5 oz.

**Part number: 731860**

**Outil polyvalent**

Pour OmniFuel, MultiFuel et VariFuel. Avec aiguille de nettoyage. Dimensions : 80 x 17 x 15 mm • 3.1" x 0.7" x 0.6". Poids: 42 g

**N° réf. de l'article: 731860**



**Service Kit**

For OmniFuel and MultiFuel EX. Weight: 58 g • 2 oz.

**Part number: 731770**

**Jeu de pièces de rechange**

Pour OmniFuel et MultiFuel EX. Poids: 58 g.

**N° réf. de l'article: 731770**



**Multi Tool**

For MultiFuel EX. Dimensions: 88 x 19 x 5 mm • 3.5" x 0.7" x 0.2". Weight: 16 g • 0.5 oz.

**Part number: 733930**

**Outil polyvalent**

Pour MultiFuel EX. Dimensions: 88 x 19 x 5 mm. Poids: 16 g

**N° réf. de l'article: 733930**



**Service Kit**

For Gravity VF and MF. Weight: 59 g • 2 oz.

**Part number: 732870**

**Jeu de pièces de rechange**

Pour Gravity VF et MF. Poids: 59 g.

**N° réf. de l'article: 732870**



**Multi Tool**

For Gravity and EtaPower. With jet cleaner. Dimensions: 88 x 19 x 5 mm • 3.5" x 0.7" x 0.2". Weight: 17 g • 0.6 oz.

**Part number: 732940**

Pour Gravity et EtaPower. Avec aiguille de nettoyage. Dimensions: 88 x 19 x 5 mm. Poids: 17 g

**N° réf. de l'article: 732940**

**Outil polyvalent**



**Fuel Pump Service Kit**

For OmniFuel, MultiFuel and VariFuel. Spare parts for Primus fuel pumps. Weight: 55 g • 1.9 oz.

**Part number: 721460**

**Kit d'entretien de la pompe à combustible**

Disponible pour les réchauds OmniFuel, MultiFuel et VariFuel. Pièces de rechange pour la réparation des pompes à combustible Primus. Poids : 55 g

**N° réf. de l'article: 721460**



- Storage box included in all service kits

**Service Kit**

For EtaPower MF. Weight: 57 g • 2 oz.

**Part number: 734150**

**Jeu de pièces de rechange**

Pour EtaPower MF. Poids: 57 g.

**N° réf. de l'article: 734150**





# PRIMUS Spare parts for fuel pumps

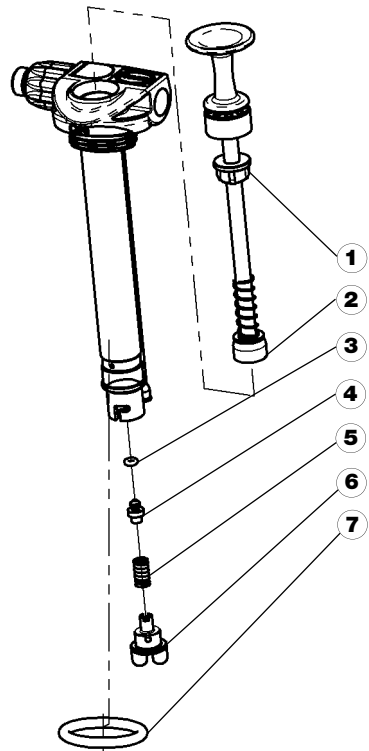

- 1 732480 Plastic bushing
  - 2 730690 Leather gasket
  - 3 730740 O-ring for non-return valve
  - 4 730730 Brass cone for non-return valve
  - 5 730750 Spring for non-return valve
  - 6 730760 Top for non-return valve
  - 7 732470 Gasket
- 730710 Leather grease  
721460 Fuel pump maintenance kit

<b>ErgoPump™ 732231</b> (MultiFuel, OmniFuel, Gravity MF & EtaPower MF) ❄️		
	102 g 3.6 oz.	
	66 x 41 x 179 mm 2.6" x 1.6" x 7"	

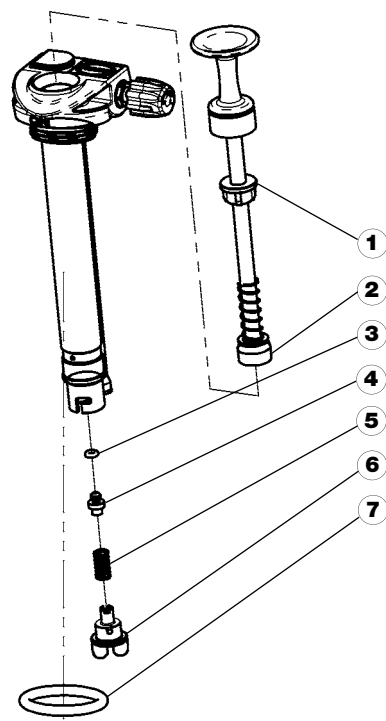

<b>ErgoPump™ 732240</b> (VariFuel & Gravity VF) ❄️		
	105 g 3.7 oz.	
	61 x 41 x 179 mm 2.4" x 1.6" x 7"	

# PRIMUS Spare parts for discontinued products

326683/326684 LiteTrail



- 1 732440 O-ring
- 2 731840 Jet nipple 0.37 mm
- 3 721000 Piezo igniter

327383 Titanium

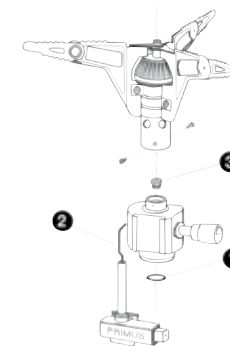

- 1 732440 O-ring
- 2 732020 Piezo igniter
- 3 731840 Jet nipple 0.37 mm

321183/321184 Micro

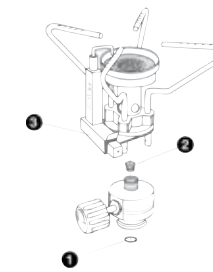

- 1 732440 O-ring
- 2 732060 Jet nipple 0.30 mm
- 3 732050 Piezo igniter

324383 PowerCook

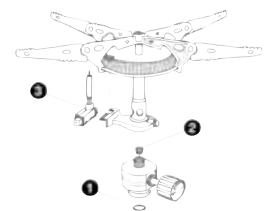

- 1 732440 O-ring
- 2 732030 Jet nipple 0.43 mm
- 3 732040 Piezo igniter

224383 ClassicTrail

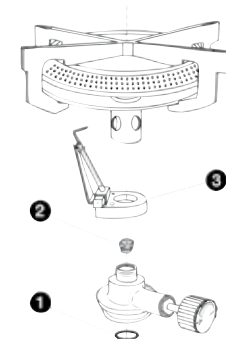

- 1 732440 O-ring
- 2 731840 Jet nipple 0.37 mm
- 3 720120 Piezo igniter

321383/93 MicronStove

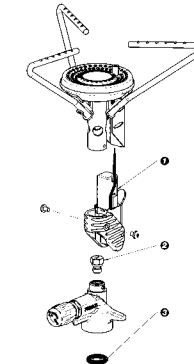

- 1 732110 Piezo igniter
  - 2 732060 Jet nipple 0.30 mm
- 732440 O-ring

327083/84 TechnoTrail, 327093/94 TechnoTrail II

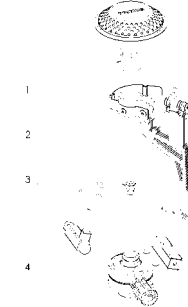

- 2 731840 Jet nipple 0.37 mm
- 3 732340 Piezo igniter for 327093/94
- 731810 Piezo igniter for 327083/84
- 4 732440 O-ring

327983/84 Gravity EF

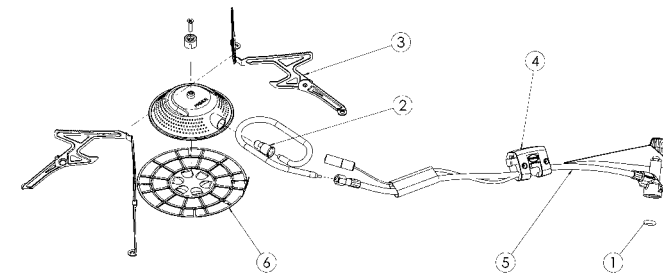

- 1 732440 O-ring
- 2 732880 Jet nipple 0.45 mm
- 3 732860 Grid & leg kit
- 732900 Piezo igniter
- 4 732910 Hose
- 5 732890 Heat shield
- 6 733920 Burner

328084/85 Gravity VF, 328184/85 Gravity MF

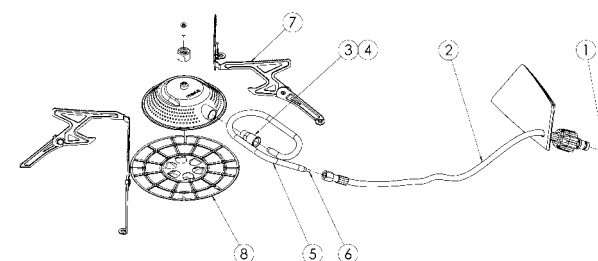

- 1 732930 O-ring (for ErgoPump)
- 2 732920 Hose
- 3 732820 Jet nipple 0.40 mm
- 4 732830 Jet nipple 0.35 mm
- 5 732840 Generator tube
- 6 732850 Cleaning wire
- 7 732860 Grid & leg kit
- 7 732890 Heat shield
- 8 732940 Multi tool
- 732870 Service & maintenance kit
- 733920 Burner



# PRIMUS Spare parts for discontinued products

- 1 730650** O-ring (for old fuel pump)
- 732930** O-ring (for ErgoPump)
- 2 721860** Hose (for old fuel pump)
- 732490** Hose (for ErgoPump)
- 3 730680** Flame spreader
- 4 730670** Jet nipple 0.28 mm
- 5 730660** Jet nipple 0.35 mm
- 6 730640** Gasket
- 7 721450** Priming pad
- 8 730610** Cleaning wire
- 9 732220** Stove body
- 10 730630** Washer
- 11 730620** Brass nut
- 731860** Multi tool
- 731910** Cleaning needle
- 721290** Service & maintenance kit

327883 VariFuel

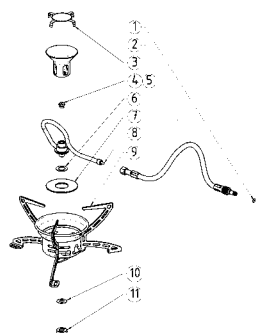

328883/84 Multifuel

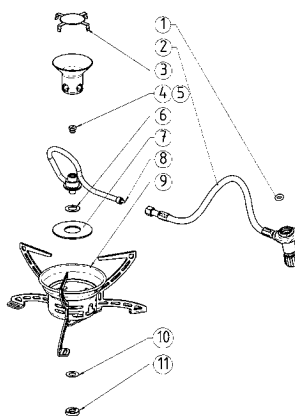

- 1 732440** O-ring
- 2 721360** Hose incl. valve
- 3 730680** Flame spreader
- 4 730670** Jet nipple 0.28 mm
- 5 730660** Jet nipple 0.35 mm
- 6 730640** Gasket
- 7 721450** Priming pad
- 8 730610** Cleaning wire
- 9 732220** Stove body
- 10 730630** Washer
- 11 730620** Brass nut
- 731860** Multi tool
- 731910** Cleaning needle
- 721290** Service & maintenance kit

721260 Fuel Pump  
(for MultiFuel & OmniFuel)

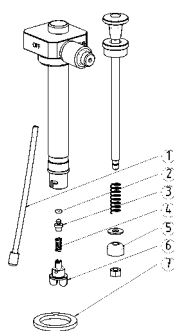

- 1 721990** Suction pipe
- 2 730740** O-ring for non-return valve (mod. 1999-)
- 3 730730** Brass cone for non-return valve (mod. 1999-)
- 4 730750** Spring for non-return valve (mod. 1999-)
- 5 730690** Leather gasket
- 6 730760** Top for non-return valve (mod. 1999-)
- 7 730700** Gasket
- 730710** Leather grease
- 731660** Non-return valve (mod. 1998)
- 721460** Fuel pump maintenance kit

721550 Fuel Pump  
(for VariFuel)

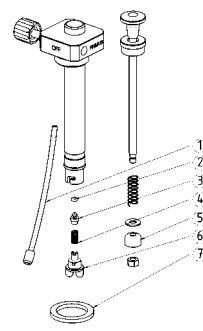

323083 Classic TrekkLite

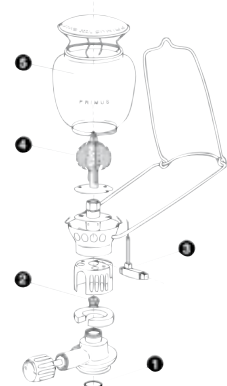





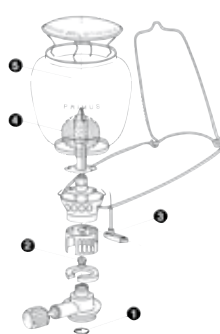

































- 1 732440** O-ring
- 2 732070** Jet nipple 0.12 mm
- 3 732080** Piezo igniter
- 4 730800** Mantle
- 5 721490** Glass













































324083 Classic MoonLite













































































- 1 732440** O-ring
- 2 732100** Jet nipple 0.14 mm
- 3 732090** Piezo igniter
- 4 730800** Mantle
- 5 720182** Glass





# PRIMUS Product Summary

Product	Item details & product number	Masterpack	EAN-barcode
	PRIMUS EtaPower™ MF - incl. fuel bottle 734120 - without piezo ignition 352085 (Canadian)	6	
	PRIMUS EtaPower™ EF - with piezo ignition 351011	6	
	PRIMUS EtaPower™ EF Trail - with piezo ignition 351083	6	
	PRIMUS EtaPackLite™ - with piezo ignition 354083	6	
	PRIMUS EtaExpress™ - with piezo ignition 353083	6	
	PRIMUS OmniFuel™ - without piezo ignition 328984	6	
	PRIMUS OmniFuel™ - incl. fuel bottle 721950 - without piezo ignition 328985	6	
	PRIMUS MultiFuel EX - without piezo ignition 328894	6	
	PRIMUS Gravity™ II MF - without piezo ignition 328194	6	
	PRIMUS Gravity™ II EF - with piezo ignition 327993	6	
	PRIMUS ExpressSpider™ - without piezo ignition 328484	6	
	PRIMUS ExpressStove™ - without piezo ignition (blister pack, non EU) 321474	6	
	PRIMUS ExpressStove™ - with piezo ignition (blister pack, non EU) 321473	6	
	PRIMUS TiLite™ - with piezo ignition 324680	6	
	PRIMUS MicronStove™ Ti - without piezo ignition 321386	6	
	PRIMUS Atle Stove - with 1" US connection 329985	2	
	PRIMUS Vidar BBQ 440010	2	
	PRIMUS Atle Stove & BBQ 320485	2	
	PRIMUS Atle Dual Stove & BBQ 320585	2	
	PRIMUS MicronLantern™ - with piezo ignition (steel mesh) 221383	6	
	PRIMUS MicronLantern™ - with piezo ignition (glass) 221363	6	

Product	Item details & product number	Masterpack	EAN-barcode
	PRIMUS Tor Sr. Lantern - with piezo ignition 216961	4	
	PRIMUS Tor Jr. Lantern - with piezo ignition 217971	4	
	PRIMUS Camping Lantern - Mini 372000	6	
	PRIMUS Camping Lantern - Pocket 372010	6	
	PRIMUS Camping Lantern 372020	6	
	PRIMUS Solar Camping Lantern 372030	6	
	PRIMUS PrimeLite™ Race 366001	6	
	PRIMUS PrimeLite™ Compact Adventure 364501	6	
	PRIMUS PrimeLite™ Compact Trekk 363501	6	
	PRIMUS PrimeLite™ Power Eye 362501	6	
	PRIMUS PrimeLite™ Eye 361501	6	
	PRIMUS PrimeLite™ Eye - mixed fashion colours 361502	6	
	PRIMUS PrimeTorch™ 101 371010	6	
	PRIMUS PrimeTorch™ 201 371020	6	
	PRIMUS PrimeTorch™ 601 371030	6	
	PRIMUS PrimeTorch™ 611 371040	6	
	PRIMUS PrimeTorch™ 701 371080	6	
	PRIMUS PrimeTorch™ 801 - with US-connector 371075	6	
	PRIMUS Bifrost H4 421002	2	
	PRIMUS Bifrost H6 422002	2	
	PRIMUS Bifrost Y6 423002	2	
	PRIMUS Shelter 425010	2	















































Product	Item details & product number	Masterpack	EAN-barcode
	PRIMUS Tarp - with poles & ropes 426010	2	
	PRIMUS Tarp LW - without poles 426020	2	
	PRIMUS SleepRest - M 734080	6	
	PRIMUS SleepRest - L 734070	6	
	PRIMUS SleepRest Chair - M 734530	6	
	PRIMUS SleepRest Chair - L 734531	6	
	PRIMUS SeatRest - M 734100	6	
	PRIMUS SeatRest - L 734090	6	
	PRIMUS EtaPower™ Pot 1 L 734110	6	
	PRIMUS EtaPower™ Pot 1.2 L 734630	6	
	PRIMUS EtaPower™ Pot 1.7 L 733880	6	
	PRIMUS EtaPower™ Pot 2.1 L 733890	6	
	PRIMUS EtaPower™ Pot 2.9 L 734210	6	
	PRIMUS LiTech Super Set - hard anodized aluminium 733310	6	
	PRIMUS LiTech Cooking Set - hard anodized aluminium 731691	6	
	PRIMUS LiTech Trek Kettle - hard anodized aluminium 1 L 731722	6	
	PRIMUS LiTech Frying Pan - hard anodized aluminium 731711	6	
	PRIMUS Eta CampLite Pot 1.7 L 734540	6	
	PRIMUS Eta CampLite Pot 2.1 L 734550	6	
	PRIMUS Eta CampLite Pot 2.9 L 734560	6	
	PRIMUS LiTech Coffee/Tea Kettle - hard anodized aluminium 0.9 L 731701	6	
	PRIMUS LiTech Coffee/Tea Kettle - hard anodized aluminium 1.5 L 733810	6	
	PRIMUS Coffee/Tea Press Kit 734650	6	

Product	Item details & product number	Masterpack	EAN-barcode
	PRIMUS Coffee/Tea Press 734520	6	
	PRIMUS Lid/Frying pan 734590	10	
	PRIMUS Lid for 1.7 L pots 734600	10	
	PRIMUS Lid for 2.1 & 2.9 L pots 734610	10	
	PRIMUS Pot Gripper 731760	10	
	PRIMUS EtaPower™ Insulation Bag 734200	6	
	PRIMUS Super Pouch 733910	6	
	PRIMUS C&H Vacuum Bottle - 0.25 L 734492	6	
	PRIMUS C&H Vacuum Bottle - 0.35 L 732352	6	
	PRIMUS C&H Vacuum Bottle - 0.50 L 732362	6	
	PRIMUS C&H Vacuum Bottle - 0.75 L 732372	6	
	PRIMUS C&H Vacuum Bottle - 1.0 L 732382	6	
	PRIMUS C&H Food Vacuum Bottle - 1.2 L 732782	6	
	PRIMUS C&H Food Vacuum Bottle - 1.5 L 732792	6	
	PRIMUS C&H Lunch Jug - 0.35 L 733772	6	
	PRIMUS C&H Lunch Jug - 0.50 L 733782	6	
	PRIMUS C&H Commuter Mug - 0.4 L 733832	6	
	PRIMUS Commuter Mug - 0.4 L (red) 733842	6	
	PRIMUS Commuter Mug - 0.4 L - Mixed fashion colours 733849	6	
	PRIMUS Oval Drinking Bottle - aluminium, 0.4 L 734502	6	
	PRIMUS Drinking Bottle - aluminium, 0.6 L 732202	6	
	PRIMUS Drinking Bottle - aluminium, 1.0 L 732212	6	
	PRIMUS Drinking Bottle - stainless steel, 0.6 L 732203	6	



Product	Item details & product number	Masterpack	EAN-barcode
	PRIMUS Drinking Bottle - stainless steel, 1.0 L 732213	6	
	PRIMUS Outdoor Bottle - stainless steel, 0.6 L 732801	6	
	PRIMUS Outdoor Bottle - stainless steel, 1.0 L 732811	6	
	PRIMUS Titanium Cutlery Kit 730841	10	
	PRIMUS Field Cutlery Kit - stainless steel 730830	10	
	PRIMUS Lightweight Cutlery Kit - PC-plastic 732771	10	
	PRIMUS Folding Spork - Red, pin-pack 734010	10	
	PRIMUS Folding Spork - Black, pin-pack 734011	10	
	PRIMUS Folding Spork - Green, pin-pack 734012	10	
	PRIMUS Folding Spork - White, pin-pack 734013	10	
	PRIMUS Folding Spork - Red (bulk, pack of 48) 734014	1	
	PRIMUS Folding Spork - Black (bulk, pack of 48) 734015	1	
	PRIMUS Folding Spork - Green (bulk, pack of 48) 734016	1	
	PRIMUS Folding Spork - White (bulk, pack of 48) 734017	1	
	PRIMUS Folding Spork - Mixed standard colours, display tube, pack of 200 734018	1	
	PRIMUS Folding Spork - Mixed standard colours, display box, pack of 48 734019	1	
	PRIMUS Folding Spork - Mixed fashion colours, display tube, pack of 200 734020	1	
	PRIMUS Meal Set - Red 734000	6	
	PRIMUS Meal Set - Black 734001	6	
	PRIMUS Meal Set - Green 734002	6	
	PRIMUS Field Cup Set - Red 734700	6	
	PRIMUS Field Cup Set - Black 734701	6	

Product	Item details & product number	Masterpack	EAN-barcode
	PRIMUS Field Cup Set - Green 734702	6	
	PRIMUS Field Cup Set - Mixed fashion colours 734703	6	
	PRIMUS Field Cup Set - Mixed fashion colours incl. display 734704	24	
	PRIMUS Spice Jar - Red 734450	10	
	PRIMUS Spice Jar - Black 734451	10	
	PRIMUS Spice Jar - Green 734452	10	
	PRIMUS Spice Jar - Mixed standard colours, display tube, pack of 102 734458	1	
	PRIMUS Outdoor Cup - Red 734460	10	
	PRIMUS Outdoor Cup - Black 734461	10	
	PRIMUS Outdoor Cup - Green 734462	10	
	PRIMUS 4 Season Mug - 0.2 L 732250	6	
	PRIMUS 4 Season Mug - 0.3 L 732260	6	
	PRIMUS Suspension Kit - for all stoves with three pot supports 721220	10	
	PRIMUS Suspension Kit - for all stoves with four pot supports 733320	10	
	PRIMUS Windscreen and Heat Reflector Set 721720	10	
	PRIMUS Windscreen - ExpressStove, MicronStove Ti, TiLite, ClassicTrail 734670	6	
	PRIMUS Toaster 720661	10	
	PRIMUS Foot Rest - also fits 2206 & Cassette Gas 721171	10	
	PRIMUS Ignition Steel - Small 733331	10	
	PRIMUS Ignition Steel - Medium 732391	10	
	PRIMUS Ignition Steel - Large 732401	10	
	PRIMUS PowerLighter - Black 733307	10	
	PRIMUS PowerLighter - Red 733308	10	







Product	Item details & product number	Masterpack	EAN-barcode
	PRIMUS Filling adapter 733870	10	
	PRIMUS Bike Clip - For PrimeLite™ CT, CA, E, PE & Race headlamps 734230	6	
	Mantle - (pack of 3) 730800	20	
	Mantle - (pack of 3) 800801	20	
	Mantle - (pack of 3) 800901	20	
	Lantern Glass - for 3240 720182	12	
	Lantern Glass - for 2245/3230 721490	12	
	Lantern Glass - for 221363 734720	12	
	PRIMUS ErgoPump - for 3281/3288/3289/3520 732231	6	
	PRIMUS ErgoPump for 3278/3280 732240	6	
	PRIMUS Multi Tool - for 3278/328883/328885/3289 731860	10	
	PRIMUS Multi Tool - 328894/328895 733930	10	
	PRIMUS Multi Tool - for 3279/3280/3281/3510/3520 732940	10	
	Service Kit - for fuel pump 721260/721550/732230/732240 721460	10	
	Service Kit - for 3278/328883/328885 721290	10	
	Service Kit - for 328894/328895/3289 731770	10	
	Service Kit - for 3280/328184/328185 732870	10	
	Service Kit - for 328194/328195 734340	10	
	Service Kit - for 3520 734150	10	
	PRIMUS Fuel Bottle 0.35 L 734120	6	
	PRIMUS Fuel Bottle 0.6 L 721950	6	
	PRIMUS Fuel Bottle 1.0 L 721960	6	
	PRIMUS Fuel Bottle 1.5 L 732530	6	







































Product	Item details & product number	Masterpack	EAN-barcode
	PRIMUS Fuel Bottle 0.35 L 734121	6	
	PRIMUS Fuel Bottle 0.6 L 721951	6	
	PRIMUS Fuel Bottle 1.0 L 721961	6	
	PRIMUS Fuel Bottle 1.5 L 732531	6	
	PRIMUS PowerFuel 1.0 L 220994	6	
	PRIMUS Cassette Gas 250 g 220893	28	
	PRIMUS PowerGas 100 g 220694	24	
	PRIMUS PowerGas 230 g 220794	24	
	PRIMUS PowerGas 450 g 220294	12	
	PRIMUS Propane Fuel 1 lb. 200593	12	
	O-ring (pack of 2) - for gas stoves & lanterns (888006 & 888506) 732440	20	
	O-rings (pack of 2+2) - for Duo 224543/321443/321444/327743 733790	20	
	O-ring (pack of 5) - for ErgoPump 3278/3280 732930	20	
	O-ring (pack of 5) - for old pump connection 3278 730650	10	
	O-ring (pack of 5) - non-return valve for all fuel pumps 730740	10	
	Piezo igniter incl. holder - for 2243 720120	10	
	Piezo igniter incl. holder - for 3211 732050	10	
	Piezo igniter incl. holder - for 3213/3214/3530 732110	10	
	Piezo igniter - for 3243 732040	10	
	Piezo igniter incl. holder - for 3266 721000	10	
	Piezo igniter incl. holder - for 3270 733340	10	
	Piezo igniter incl. holder - for 3274 732020	10	
	Piezo igniter incl. holder - for 327783 731590	10	

Product	Item details & product number	Masterpack	EAN-barcode
	Piezo igniter - for 327743/327793 734380	10	
	Piezo igniter incl. holder - for 327983 732900	10	
	Piezo igniter - for 3510 733960	10	
	Piezo igniter - for 2213 732460	10	
	Piezo igniter - for 2245 730850	10	
	Piezo igniter - for 3240 732090	10	
	Piezo igniter - for 3230 732080	10	
	Piezo igniter - for 327993 734580	10	
	Piezo igniter - for 3540 734640	10	
	Jet nipple 0.37 (pack of 5) - for 2243/3266/3270/3274 731840	10	
	Jet nipple 0.43 (pack of 5) - for 3243 732030	10	
	Jet nipple 0.40 (pack of 5) - for 3277 732000	10	
	Jet nipple 0.28 (pack of 5) - Kerosene/paraffin for 3278/3288/3289 730670	10	
	Jet nipple 0.30 (pack of 5) - for 3211/3213/2213 732060	10	
	Jet nipple 0.32 (pack of 5) - for 3214/3530 734350	10	
	Jet nipple 0.35 (pack of 5) - Gas, white gas, petrol for 3278/328883 730660	10	
	Jet nipple 0.37 (pack of 5) - White gas, petrol/gasoline for 328894/328895/3289 731800	10	
	Jet nipple 0.45 (pack of 5) - Gas for 328894/328895/3289 731790	10	
	Jet nipple 0.39 (pack of 5) - for 324680 734660	10	
	Jet nipple 0.22 (pack of 5) - Kerosene/paraffin for 3520 734320	10	
	Jet nipple 0.26 (pack of 5) - Kerosene/paraffin for 328194/328195 734290	10	
	Jet nipple 0.28 (pack of 5) - White gas, petrol/gasoline for 3520 734330	10	
	Jet nipple 0.32 (pack of 5) - Gas for 3284/3510/3520 733950	10	

Product	Item details & product number	Masterpack	EAN-barcode
	Jet nipple 0.35 (pack of 5) - Kerosene/paraffin for 3280/328184/328185 732830	10	
	Jet nipple 0.37 (pack of 5) - White gas, petrol/gasoline for 328194/328195 734300	10	
	Jet nipple 0.40 (pack of 5) - White gas, petrol/gasoline for 3280/328184/328185 732820	10	
	Jet nipple 0.42 (pack of 5) - Gas for 327993/328194/328195 734310	10	
	Jet nipple 0.45 (pack of 5) - Gas for 3279/328184/328185 732880	10	
	Jet nipple 0.12 (pack of 5) - for 2213/2245/3230 732070	10	
	Jet nipple 0.14 (pack of 5) - for 3240 732100	10	
	Mesh basket - for 2213 732450	10	
	Burner - for 327983/327984/328084/328085/328184/328185 733920	6	
	Stove Body - for 3277/3278/328883 732220	10	
	Stove Body (old) - for 3289 732010	10	
	Stove Body - for 328894/328895 733940	6	
	Grid & Leg Kit - for 327983/327984/328084/328184 732860	6	
	Heat Shield - for 327983/327984/328084/328184 732890	10	
	Flame Spreader (pack of 5) - for 328894/328895/3289 731870	10	
	Flame Spreader (pack of 5) - for 3278/328883 730680	10	
	Priming Pad (pack of 2) - for 3278/328883 721450	20	
	Priming Pad (pack of 2) - for 328894/328895/3289 731780	20	
	Priming Pad (pack of 2) - for 3220/328194/328195 734220	20	
	Hose - for 3278 (old pump) 721860	6	
	Hose - for 3278 (ErgoPump) 732490	6	
	Hose - incl. valve for 3279/3281/3284 732910	6	

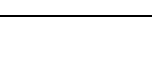

Product	Item details & product number	Masterpack	EAN-barcode
	Hose - for 3280 (ErgoPump) 732920	6	
	Hose incl. valve - for 327793/3288 721360	6	
	Hose incl. valve - for 3289 731930	6	
	Washer (pack of 5) - for 3277/3278/328883 730630	10	
	Brass Nut (pack of 5) - for 3277/3278/328883 730620	10	
	Brass Screw (Pack of 5) - for 328894/328895/3289 731940	10	
	Holder (pack of 5) - for priming pad 328894/328895/3289 731880	10	
	Fuel Filter (pack of 5) - for 3289 731890	10	
	Spindle incl. o-ring (pack of 5) - for 3289 731900	10	
	Thread Handle (pack of 5) - for 3289 731920	10	
	Cleaning Wire (pack of 5) - for 3278/328883 730610	10	
	Cleaning Wire (pack of 5) - for 3280/3281/3284/3520 732850	10	
	Cleaning Needle (pack of 2) - for 3278/3288/3289 731910	10	
	Gasket (pack of 5) - for 3277/3278/328883 730640	10	
	Gasket (pack of 5) - for old fuel pump 721260/721550 730700	10	
	Gasket (pack of 5) - for ErgoPump 732230/732240 732470	10	
	Leather Gasket (pack of 5) - for all fuel pumps 730690	10	
	Leather Grease (pack of 5) - for all fuel pumps 730710	10	
	Suction Pipe (pack of 5) - for old fuel pump 721260/721550 721990	10	
	Top for non-return valve (pack of 5) - for all fuel pumps 730760	10	
	Spring for non-return valve (pack of 5) - for all fuel pumps 730750	10	
	Brass cone for non-return valve (pack of 5) - for all fuel pumps 730730	10	
	Plastic bushing (pack of 5) - for all fuel pumps 732480	10	

Product	Item details & product number	Masterpack	EAN-barcode
	Generator Tube - for 327983/327984/328084/328085/328184/328185 732840	10	
	Generator Tube - for 328194/328195 734370	10	
	Generator Tube - for 3520 734360	10	
	Fuel Bottle Cap - for 34120/721950/721960/732530 722010	10	
	Child Safe Fuel Bottle Cap - for 734120/721950/721960/732530 734740	10	
	Quick Stopper - for Vacuum Bottle 0.35, 0.5, 0.75 & 1 L 734240	10	
	Stopper for Vacuum Bottle 0.35, 0.5, 0.75 & 1 L 734250	10	
	Stopper - for Food Vacuum Bottle 1.2 & 1.5 L 733370	10	
	Cup - for Vacuum Bottle 0.35 & 0.5 L 734260	10	
	Cup - for Vacuum Bottle 0.75 & 1 L 734270	10	
	Cup - for Food Vacuum bottle 1.2 & 1.5 L 734280	10	
	PRIMUS Electronic insert for PrimeLite Race 734570	10	
	PRIMUS Selection Guide 566021	1	
	PRIMUS Instructional Films - DVD 565990	1	
	PRIMUS Instructional Films - DVD (Exhibition loop & web films) 565991	1	
	PRIMUS Banner stand - for Eta 565996	1	
	PRIMUS Cookbook - English 565992	1	
	PRIMUS Cookbook - French 565993	1	
	PRIMUS Sticker logotype - 32 x 50 mm 565937	1	
	PRIMUS Sticker logotype - 96 x 148 mm 565936	1	
	PRIMUS Sticker logotype - 136 x 210 mm 565935	1	
	PRIMUS Sticker "Primus Was Here" - 50 x 42 mm 565966	1	
	PRIMUS Sticker "Primus Was Here" - 150 x 125 mm 565967	1	

Product	Item details & product number	Masterpack	EAN-barcode
	PRIMUS Piqué Shirt "Primus Was Here" - XS 566009	1	
	PRIMUS Piqué Shirt "Primus Was Here" - S 566010	1	
	PRIMUS Piqué Shirt "Primus Was Here" - M 566011	1	
	PRIMUS Piqué Shirt "Primus Was Here" - L 566012	1	
	PRIMUS Piqué Shirt "Primus Was Here" - XL 566013	1	
	PRIMUS Piqué Shirt "Primus Was Here" - XXL 566014	1	
	PRIMUS Cap "Primus Was Here" 565986	1	
	PRIMUS Balloons "Primus Was Here" 566002	20	
	PRIMUS Plastic Bag "Primus Was Here" 565970	1	
	PRIMUS Folding Spork "Primus Was Here" - Mixed fashion colours, display tube, pack of 200 566040	1	
	PRIMUS Display Tube "Primus Was Here" 566006	1	
	PRIMUS PrimeLite Neck Strap 565951	1	
	PRIMUS Shoulder Bag & Laptop Case 566018	1	
	PRIMUS Sample Bag 565963	1	
	PRIMUS Peg for slot-in wall 566008	6	
	PRIMUS PrimeTorch display stand 566007	6	
	PrimeLite Wooden floor display stand 565942	1	
	PrimeLite Metal desk/wall display stand 565968	1	
	PRIMUS PowerGas 100 g - empty 220600	24	
	PRIMUS PowerGas 230 g - empty 220700	24	
	PRIMUS PowerGas 450 g - empty 220200	12	



# Fuel consumption with stoves

Season Saison	Fuel Combustible	1 Day 1 Jour		Weekend (2 days) Week-end (2 jours)		Week (7 days) Semaine (7 jours)	
Summer Été	Gas Gaz	100 g	50 g	230 g	100 g	2 x 230 g	230 g
	Gasoline/petrol, kerosene/paraffin or diesel Essence/Pétrole/Gazole	0.1 l	0.06 l	0.3 l	0.18 l	0.8 l	0.5 l
Winter Hiver	Gas Gaz	230 g	100 g	450 g	230 g	450 + 230 g	450 g
	Gasoline/petrol, kerosene/paraffin or diesel Essence/Pétrole/Gazole	0.2 l	0.12 l	0.6 l	0.35 l	1.5 l	0.9 l

The table above applies to a single stove and one person, cooking an average amount of freeze-dried with coffee and tea breaks. For two people and a single stove, increase consumption by about 50 % in winter. The levels of consumption specified above should be regarded as guidelines. Variations can be expected depending, amongst other things, on the wind, temperature, number of people and type of food. Protection from the wind is of the utmost importance to keeping the consumption at a low level. Winter consumption includes melting snow. Using products from our Eta series helps to radically reduce fuel consumption, thanks to their high efficiency. This means less packaging weight and volume as well as lower carbon dioxide emissions.

Le tableau ci-dessus indique la consommation d'un réchaud pour une personne, pour la préparation normale d'aliments lyophilisés et de café ou de thé. Pour deux personnes partageant un réchaud, la consommation augmente d'environ 50 % en hiver. Les consommations ci-dessus sont uniquement indicatives. Elles peuvent en effet varier en fonction du vent, de la température, du nombre de personnes et de la nature des aliments préparés. Il est extrêmement important d'utiliser un pare-vent pour réduire la consommation de combustible. La consommation hivernale tient compte de ce qu'il faut faire fondre de la neige pour obtenir de l'eau. Lors de l'utilisation de produits issus de la série Eta, la consommation de combustible diminue énormément grâce aux degrés d'efficacité élevés de nos réchauds. Cela permet de réduire le poids et l'encombrement et également les rejets d'oxyde de carbone dans l'air.



## Energy values



Energy value Valeur énergétique	Heat kcal/kg Chaleur kcal/kg	Boiling power index Indice de puissance de chauffe
Primus gas • GPL Primus	11900	100
Propane • Propane	12000	101
Butane • Butane	11800	99
White gasoline/petrol • Essence filtrée	10200	86
Kerosene/paraffin • Pétrole	10100	85
Diesel • Gazole	9800	82
Charcoal • Charbon de bois	8400	71
Methylated spirits • Alcool à brûler	6300	53
Dry wood • Bois sec	4000	34

Different fuels and their energy value • Différent combustibles et leur valeur énergétique

### PRIMUS Outdoor Cookbook

A 16-page folder in pocket size which contains eight tasty recipes.

**Part number:**  
**565992** - English  
**565993** - French

### PRIMUS Outdoor Cookbook

Carnet de 16 pages au format de poche avec huit bons petits plats faciles à réaliser en plein air.

**N° réf. de l'article:**  
**565992** - Anglais  
**565993** - Français



### PRIMUS Stickers - Logotype

For usage inside as well as outside.

**Part number:**  
**565935** Dimensions: 136 x 210 mm • 5.3" x 8.3".  
**565936** Dimensions: 96 x 148 mm • 3.8" x 5.8".  
**565937** Dimensions: 32 x 50 mm • 1.3" x 2".

### PRIMUS Autocollant avec logo.

Pour usage à l'intérieur et l'extérieur.

**N° réf. de l'article:**  
**565935** Dimensions: 136 x 210 mm.  
**565936** Dimensions: 96 x 148 mm.  
**565937** Dimensions: 32 x 50 mm.



### PRIMUS Stickers - "Primus was here"

For usage inside as well as outside.

**Part number:**  
**565966** - 50 x 42 mm • 2" x 1.6".  
**565967** - 150 x 125 mm • 5.9" x 4.9".

### PRIMUS Autocollants - "Primus was here"

A utiliser aussi bien en intérieur qu'en extérieur.

**N° réf. de l'article:**  
**565966** - 50 x 42 mm.  
**565967** - 150 x 125 mm.



### PRIMUS Piqué shirt "Primus was here"

**Part number:**  
**566009** - XS  
**566010** - S  
**566011** - M  
**566012** - L  
**566013** - XL  
**566014** - XXL

### PRIMUS Polo "Primus was here"

**N° réf. de l'article:**  
**566009** - XS  
**566010** - S  
**566011** - M  
**566012** - L  
**566013** - XL  
**566014** - XXL



FRONT BACK

### PRIMUS Cap "Primus was here"

**Part number: 565986**

### PRIMUS Casquette "Primus was here"

**N° réf. de l'article: 565986**

